

ICF-M33RDS

SERVICE MANUAL

Ver 1.0 1999.01

AEP Model
UK Model



SPECIFICATIONS

Time display:
24-hour system

Frequency range:

Band	Frequency range	Channel step
FM	87.5 - 108 MHz	0.05*MHz(fixed)
AM	531 - 1,602 kHz	9 kHz(fixed)
LW	153 - 279 kHz	9 kHz(fixed)

* The frequency readout in the display is rounded to the nearest 0.1 MHz. (Example: The frequency of 88.05 MHz appears as "88.0" MHz.)

Indication of AM : French model

Indication of LW : AEP, UK models

Power output: 90 mW (at 10% harmonic distortion)

Output: Ⓜ (earphone) jack (minijack)

Power requirements:

3 V DC, two R6 (size AA) batteries

DC IN 3 V jack accepts: Sony AC-E30HG AC power adaptor (not supplied)

Dimensions: Approx. 165 x 82 x 36.7 mm (w/h/d) (Approx. 6½ x 3¼ x 1½ inches) not incl. projecting parts and controls

Mass: Approx. 400 g (14.3 oz) incl. batteries

Design and specifications are subject to change without notice.

FM/AM (LW) RDS RADIO

SONY®



TABLE OF CONTENTS

1. GENERAL	
Features	3
Choosing the Power Source	4
Setting the Clock	4
Operating the Radio	4
Setting the Sleep Timer	5
Using the RDS Function	5
Using Other Functions	6
Precautions	6
2. DISASSEMBLY	7
3. ELECTRICAL ADJUSTMENTS	9
4. DIAGRAMS	
4-1. Block Diagram	11
4-2. Note for Printed Wiring Boards and Schematic Diagrams	13
4-3. Printed Wiring Board – MAIN Section –	14
4-4. Printed Wiring Board – PANEL Section –	17
4-5. Schematic Diagram	21
4-6. IC Pin Function Description	28
5. EXPLODED VIEW	29
6. ELECTRICAL PARTS LIST	30

SERVICING NOTES

HOW TO CHANGED THE CERAMIC FILTERS

This model is used two ceramic filters of CF2 and CF3.

You must used same type of color marked ceramic filters in order to meet same specifications.

Therefore, the ceramic filter must changed two pieces together since it's supply two pieces in one package as a spare parts.

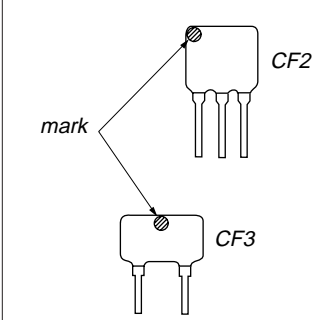
	Mark	Center frequency
	red	10.70 MHz
	blue	10.67 MHz
	orange	10.73 MHz
	black	10.64 MHz
	white	10.76 MHz

Notes on chip component replacement

- Never reuse a disconnected chip component.
- Notice that the minus side of a tantalum capacitor may be damaged by heat.

SECTION 1 GENERAL

This section is extracted from instruction manual.

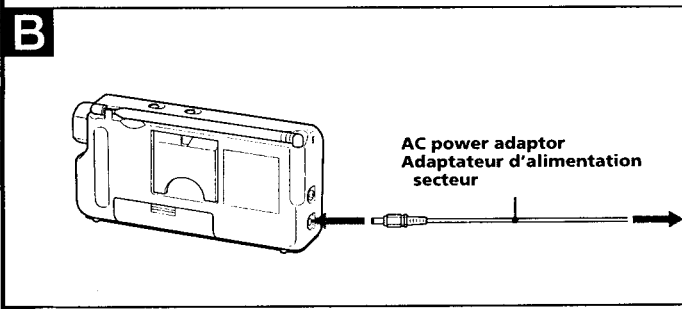
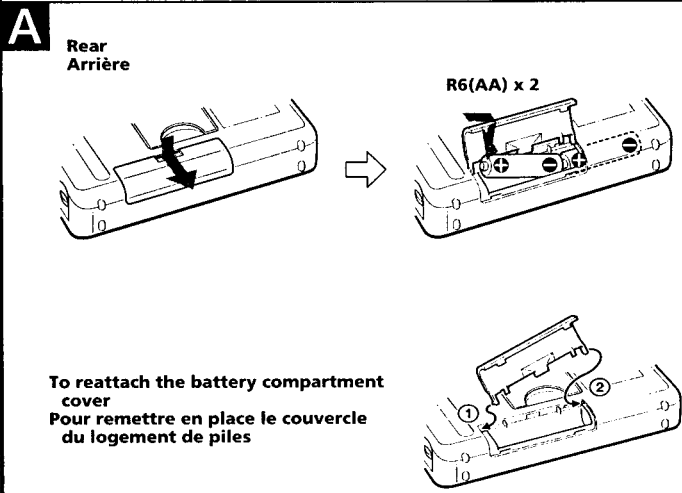
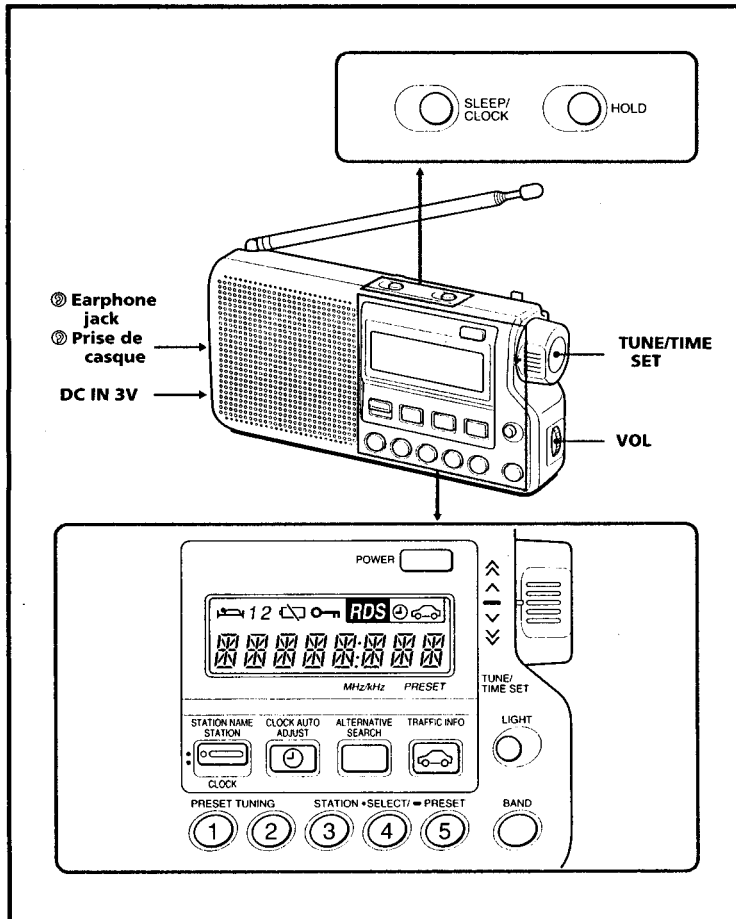

Features

What is RDS ?

The Radio Data System (RDS) is a digital information system developed for radio by the European Broadcasting Union (EBU), and was introduced in 1987. Using the 57 kHz sub-carrier for FM broadcasting, RDS enables you to receive a variety of information, such as station names and traffic information.

The availability of RDS data depends on your location. Hence, there may be areas where you cannot benefit from some of the following features:

RDS Features

SONY RDS	SONY Features
Conventional RDS Function	
CLOCK AUTO ADJUSTMENT 	<ul style="list-style-type: none"> Automatic current-time synchronization. Auto-adjustment for daylight-saving time.
CT (Clock Time) - Automatic current-time synchronization.	
STATION NAME DISPLAY 	<ul style="list-style-type: none"> For checking the name of the tuned-in station. For locating a station when its frequency is not known.
PS (Programme Service) - Displays station names in up to 8 letters.	
TRAFFIC INFORMATION 	<ul style="list-style-type: none"> Search and standby modes for receiving traffic information. Automatic switch from regular radio broadcast to traffic information provided by the EON network. Regular broadcast resumes after the interception.
TA (Traffic Announcement) via EON (Enhanced Other Networks) - Automatic selection and switch to traffic information.	
ALTERNATIVE SEARCH	<ul style="list-style-type: none"> Automatic search and switch to a frequency with a relatively stronger signal for a station broadcasting on multiple frequencies.
AF (Alternative Frequencies) - Automatic selection of a relatively stronger signal.	

Other Features

- Quartz-controlled PLL (Phase Locked Loop) synthesizer system using a microcomputer for easy pinpoint tuning.
- Preset function for up to 10 stations in FM and 5 stations in AM/LW.
- Jog tuning and digital radio frequency display for quick and precise tuning.

Choosing the Power Source

Installing the Batteries (See Fig. A)

- 1 Open the lid at the rear of the radio.
- 2 Install two R6 (size AA) batteries (not supplied) with correct polarity.
- 3 Close the lid.

Battery Life using Sony R6 (AA) batteries

Band	(Approx. hours)
FM	20
AM/LW	35

Knowing When to Replace the Batteries

- When the batteries are weak, the sound becomes weak and distorted. When the batteries are completely exhausted, the radio is inoperative and "⏻" appears in the display. Replace the batteries with new ones.
- Once "⏻" comes on in the display, it remains even after new batteries are installed. To remove "⏻" from the display, press **POWER**.
- Before replacing the batteries, make sure the radio is turned off. Replace the batteries within one minute. Otherwise, the clock setting and preset stations could be erased. In this case, set the clock and preset the stations again.

Note

- When the unit is not being used for an extended period, remove the batteries to avoid damage from battery leakage and corrosion.

Using House Current (See Fig. B)

Connect the AC power adaptor AC-E30HG (not supplied) to the DC IN 3 V jack, and plug it into a wall outlet.

Notes on the AC power adaptor

- When the AC power adaptor is not used, be sure to unplug it both from the DC IN 3 V jack and from the wall outlet.
- Use only the AC adaptor AC-E30HG (not supplied). Do not use any other AC power adaptor.

Polarity of the plug



Setting the Clock

When batteries are first installed in the unit, "0:00" flashes in the display. To set the clock, the radio should be turned off.

- 1 Press **SLEEP/CLOCK** to stop "0:00" flashing in the display.
- 2 While holding down **SLEEP/CLOCK**, turn **TUNE/TIME SET** to set the clock to the current time.

When you turn **TUNE/TIME SET** to \wedge or \vee , the time readout in the display increases or decreases, respectively, in one-second steps. Turning it to \approx or \cong causes the readout to rapidly increase or decrease, respectively.

When you release **SLEEP/CLOCK**, the clock starts operating and ":" begins to flash.

- To check the current time while listening to the radio, switch **STATION NAME** to **CLOCK**. The current time appears in the display.

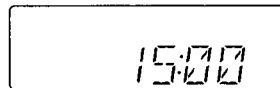

- You can also set the current time through automatic synchronization with RDS data using the CT function. (See "Setting the Clock with the CT Function".)

Operating the Radio Manual Tuning

- 1 Press **POWER**.
- 2 Adjust **VOL** (volume).
- 3 Press **BAND** to select the band. Repeated pressing of **BAND** changes the band in the following order:



* Both FM1 and FM2 refer to the same FM waveband and are differentiated solely to enable more than one station to be assigned to a preset button. (See "Preset Tuning".)

- 4 Turn **TUNE/TIME SET** upward or downward until you locate the frequency of your desired station. When you turn **TUNE/TIME SET** to \wedge or \vee , the frequency readout in the display increases or decreases, respectively. Turning it to \approx or \cong causes the readout to rapidly increase or decrease, respectively.

- To turn off the radio, press **POWER**. The display shows the current time even when the radio is turned off.

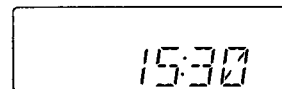

- To improve radio reception
 - FM**: Extend the telescopic antenna.
 - AM/LW**: Rotate the unit horizontally for optimum reception. A ferrite bar antenna is built in the unit.
- When you tune in to an FM station, the display may change from the frequency readout to the name of the station. This happens particularly for FM stations that carry RDS data in their frequencies. (See "Displaying the Station Name".)

Changing the Display Mode

You can change the display mode by setting the **STATION NAME** switch to either **CLOCK** or **STATION**.

STATION NAME switch set to **CLOCK**:

- When you turn on the power, the display shows the tuned-in frequency for a few seconds, and then switches to the current time while the radio is on. To check the radio frequency or station name, switch **STATION NAME** to **STATION**.
- You can tune in to a station by turning **TUNE/TIME SET** to the desired frequency. The display shows the frequency for a few seconds before reverting to the current time.
- When the unit is receiving RDS traffic information (see "Receiving Traffic Information"), the display shows the name of the broadcasting station for a few seconds before reverting to the current time.

Preset Tuning

You can preset up to 10 stations in FM (5 stations in FM1, 5 stations in FM2), and 5 stations in AM /LW.

Presetting a Station

Example: To preset a station on the FM 90 MHz frequency onto preset button 2 of FM2.

- 1 Press **POWER**.
- 2 Press **BAND** to select FM2.
- 3 Tune in to the FM 90 MHz frequency. Press and hold down the desired preset button. (2, in this case.) "2", the preset button number, flashes in the display. A beep sounds, and "2" stops flashing and remains in the display to indicate the presetting is successful.

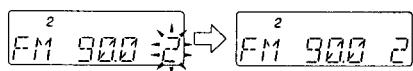

- To preset other stations, repeat the above steps.
- To replace the station assigned to a preset button, follow the above steps and, in step 3, press the preset button you wish to reset.

Tuning in to a Preset Station

- 1 Press **POWER**.
- 2 Press **BAND** to select the band.
- 3 Press the desired preset button.
- 4 Adjust **VOL** (volume).

Setting the Sleep Timer

By using the sleep timer function, you can fall asleep to the sound of the radio. The function, when activated, turns the radio off after 60 minutes.

- 1 Press **POWER**.
- 2 Press **BAND** to select the band.
- 3 Tune in to the desired station.
- 4 Adjust **VOL** (volume).
- 5 Press **SLEEP/CLOCK**. A beep sounds, and "SLEEP 60" and "⏰" appear in the display to indicate the setting is successful.

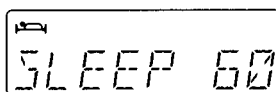

- When you release **SLEEP/CLOCK**, the previous display comes on again.
- To turn off the sleep timer before the end of the timer duration, press **POWER**.
- When you press **SLEEP/CLOCK** while the timer has been activated, the elapsed time will be erased and the timer duration will begin from the start.

Using the RDS Function

In this radio, the following functions are available for receiving RDS data:

Displaying the Station Name

You can set the unit to display the name of the tuned-in station.

- 1 Press **BAND** to select the FM band. (You can select either FM1 or FM2.)
- 2 Tune in to the desired station.

When the radio is receiving RDS data, "RDS" and the name of the station transmitting the data appear in the display. If no RDS data is received, "RDS" automatically goes off.

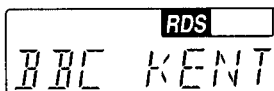

Notes

- RDS data can only be received on the FM band.
- The RDS function of this radio will not be activated if the tuned-in FM station does not transmit RDS data. The function may also not work properly in areas where RDS transmissions are in an experimental stage.

Locating Better Reception

Some broadcasters, such as the BBC, broadcast on several frequencies. The **ALTERNATIVE SEARCH** function enables the unit, through AF (List of Alternative Frequencies) data, to locate another frequency with a stronger signal, and to automatically switch to that frequency.

- 1 Press and hold down **ALTERNATIVE SEARCH** until the unit locates a better reception.

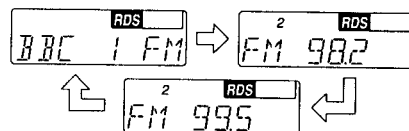

If no alternative frequency is found, "NO AF" appears in the display.

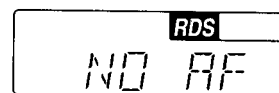

Note

- When a station that transmits RDS data is preset, its AF data is recorded in the memory of the unit. Hence, when the preset station is tuned in and no RDS data is received, the **ALTERNATIVE SEARCH** function automatically scans for RDS data among the other frequencies of the station through the AF data. The display of the unit will show the rapidly changing frequencies during the search. If a frequency with RDS data is detected, the unit switches to that frequency. If RDS data is not detected, the unit reverts to the frequency initially tuned in.

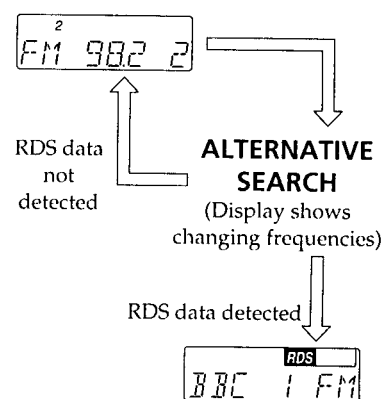

Receiving Traffic Information

The **TRAFFIC INFO** function searches and places the unit on a standby mode to receive traffic information facilitated by the EON* network, through detecting the TP (Traffic Program) and TA (Traffic Announcement) signals in the RDS data.

When traffic information is received, the unit automatically switches from the regular radio broadcast of the tuned-in station to the incoming traffic message. After the message, the unit switches back to the regular radio broadcast.

- 1 Press **BAND** to select the FM band. (You can select either FM 1 or FM 2). If the station selected transmits RDS data, "RDS" lights up.
- 2 Press **TRAFFIC INFO** for "📻" to light up along with "RDS". The unit is now on standby to receive traffic information.

- When traffic information is received, "📻" starts to flash, and the unit switches over to the traffic information.



- To stop the reception of traffic information and to return to your tuned-in station, press **TRAFFIC INFO**.

Notes

- If the tuned-in station is not a traffic information station nor a station in an EON network, a beep sounds.
- Switching the band from FM to AM while "📻" is lit in the display causes "📻" to disappear. "📻" does not come back on when the band is switched back to FM or if the unit is turned off and then on again.
- When **POWER** is turned off, traffic information will not be received.

*Enhanced Other Networks—EON

An EON network consists of a group of stations whereby a listener, who is tuned in to a participating station using a RDS compatible radio, can automatically receive RDS data transmitted by other stations in the network.

This unit is equipped to receive RDS traffic information provided by EON networks.

Setting the Clock Using the CT Function

The CT function of the RDS enables the built-in clock of the unit to automatically synchronize with CT data being transmitted.

- 1 Switch **STATION NAME** to **CLOCK** when "RDS" is lit in the display. The current time appears in the display.
- 2 Press **CLOCK AUTO ADJUST**. This activates the CT function and "🕒" starts to flash in the display. When the current time is synchronized, "🕒" stops flashing and remains in the display.



To cancel the function, press **CLOCK AUTO ADJUST**. "🕒" disappears in the display.

Notes

- If the unit does not receive CT data after 2 minutes, "NO CT" appears in the display. The function is then automatically cancelled.
- The current time on your unit, set through this mode, will be as accurate as that of the CT data received.
- The CT function may not work in some areas or on certain frequencies. In such a case, "🕒" does not come on in the display.

Using Other Functions

LIGHT Function

To view the display in the dark:

- 1 Press **LIGHT**. The light on the unit comes on for 10 seconds.

When you operate your unit while the light is on, the light stays on for longer than 10 seconds.

HOLD Function

To prevent accidental operation of the unit:

- 1 Press **HOLD**. "🔒" appears in the display to indicate all the function buttons are locked and inoperative.

To cancel the function, press **HOLD** again. "🔒" disappears in the display.

Precautions

- Do not open the unit. Refer servicing to qualified personnel only.
- Operate the unit using only the power sources given in "Specifications".
- For AC operation, use the AC power adaptor recommended for this unit; do not use any other type.
- Avoid exposure to temperature extremes, direct sunlight, moisture, sand, dust, or mechanical shock. Never leave the unit in a car parked in the sun.
- The name plate indicating operating voltage, etc., is located at the rear.
- Should any solid object or liquid fall into the unit, disconnect the AC power adaptor or remove the batteries, and have the unit checked by qualified personnel before operating it any further.
- Since a strong magnet is used for the speaker, keep personal credit cards using magnetic coding or spring-wound watches away from the unit to prevent possible damage from the magnet.
- When the casing becomes soiled, clean it with a soft cloth dampened with mild detergent solution. Never use abrasive cleansers or chemical solvents, as they may mar the casing.
- In vehicles or buildings, radio reception may be difficult or noisy. Try listening near a window.

If you have any questions or problem concerning your unit, please consult the nearest Sony dealer.

SECTION 2 DISASSEMBLY

- This set can be disassembled in the order shown below.

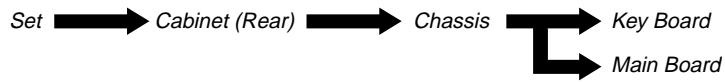

Note: Follow the disassembly procedure in the numerical order given.

CABINET (REAR)

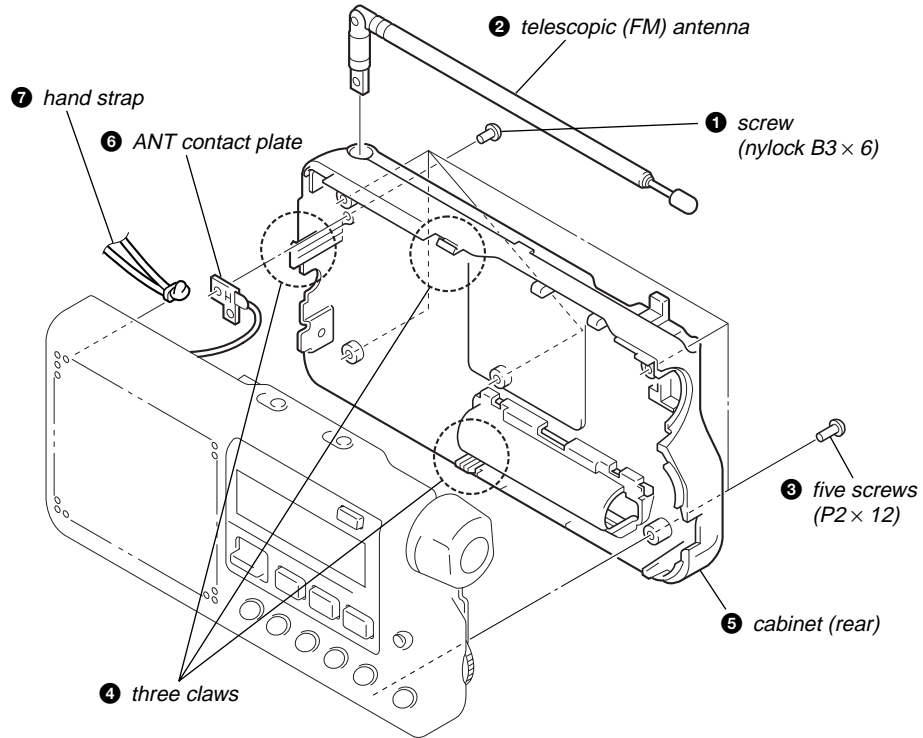

CHASSIS

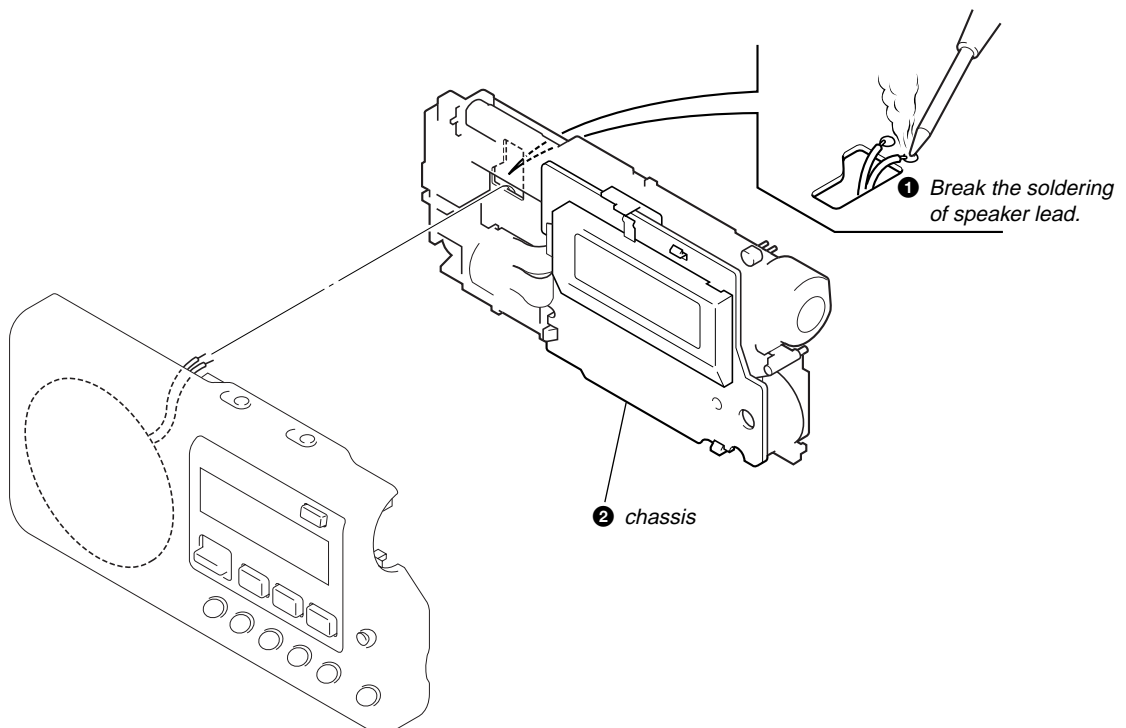

KEY BOARD

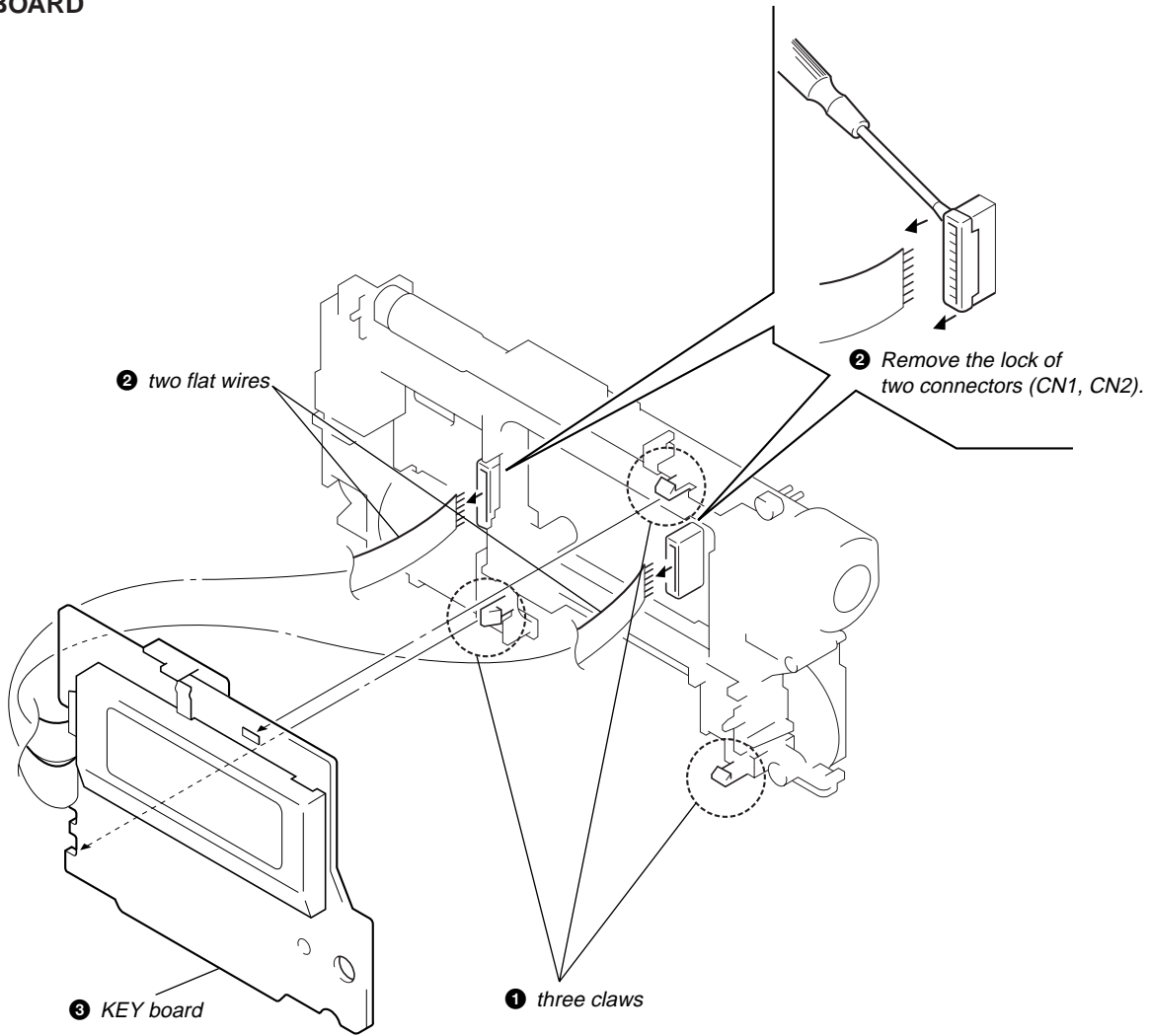

MAIN BOARD

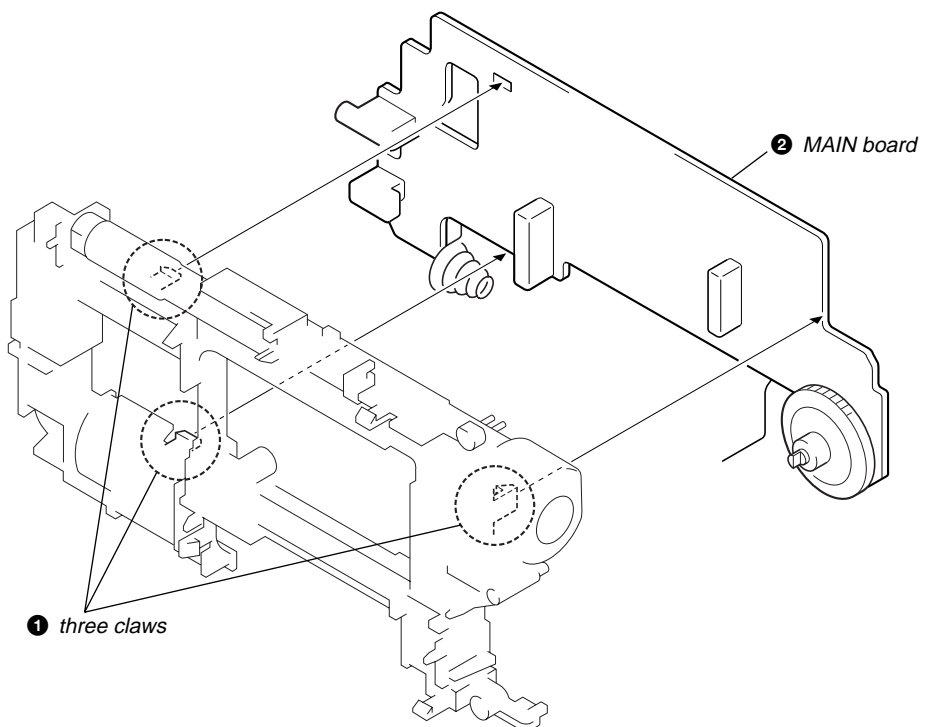

SECTION 3 ELECTRICAL ADJUSTMENTS

0 dB = 1 μ V

[FM]

Setting:

Band switch: FM

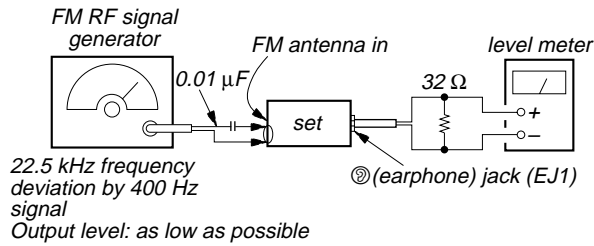

[AM (LW)*]

* AM: French model

LW : AEP, UK models

Setting:

Band switch: AM (LW)

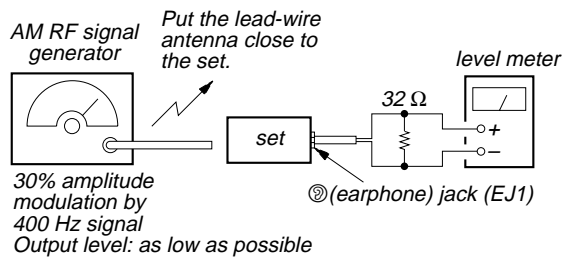

- Repeat the procedures in each adjustment several times, and the frequency coverage and tracking adjustments should be finally done by the trimmer capacitors.
- Remove FM antenna in FM adjustments.

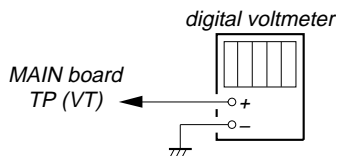

Adjustment Location: Main Board (See page 10)

FM VCO VOLTAGE ADJUSTMENT

Adjustment Part	Frequency Display	Reading On Digital voltmeter
L 4	87.5 MHz	2.5 V \pm 0.1 V
confirmation	108.0 MHz	Less than 10.7 V

FM TRACKING ADJUSTMENT

Adjust for a maximum reading on level meter.

L3	87.5 MHz
CT2	108 MHz

AM (LW) VCO VOLTAGE ADJUSTMENT

Adjustment Part	Frequency Display	Reading On Digital voltmeter
L 5	531 kHz (153 kHz)	2.7 V \pm 0.1 V (3.3 V \pm 0.1V)
confirmation	1,602 kHz (279 kHz)	Less than 9.5 V (7.5 V)

AM (LW) TRACKING ADJUSTMENT

Adjust for a maximum reading on level meter.

L2	621 kHz (162 kHz)
CT1	1,404 kHz (243 kHz)

AM IF ADJUSTMENT

Adjust for a maximum reading on level meter.

T1	450 kHz
----	---------

(): AEP, UK models

Adjustment Location:

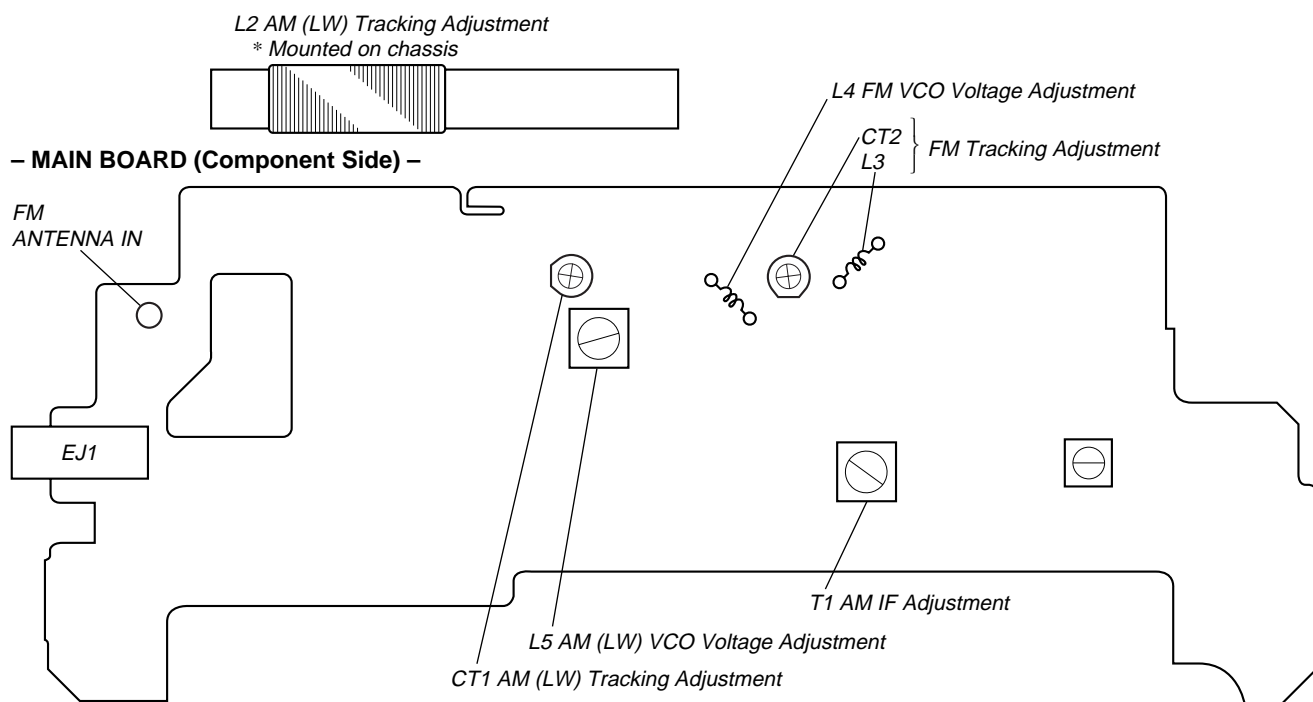

- MAIN BOARD (Conductor Side) -

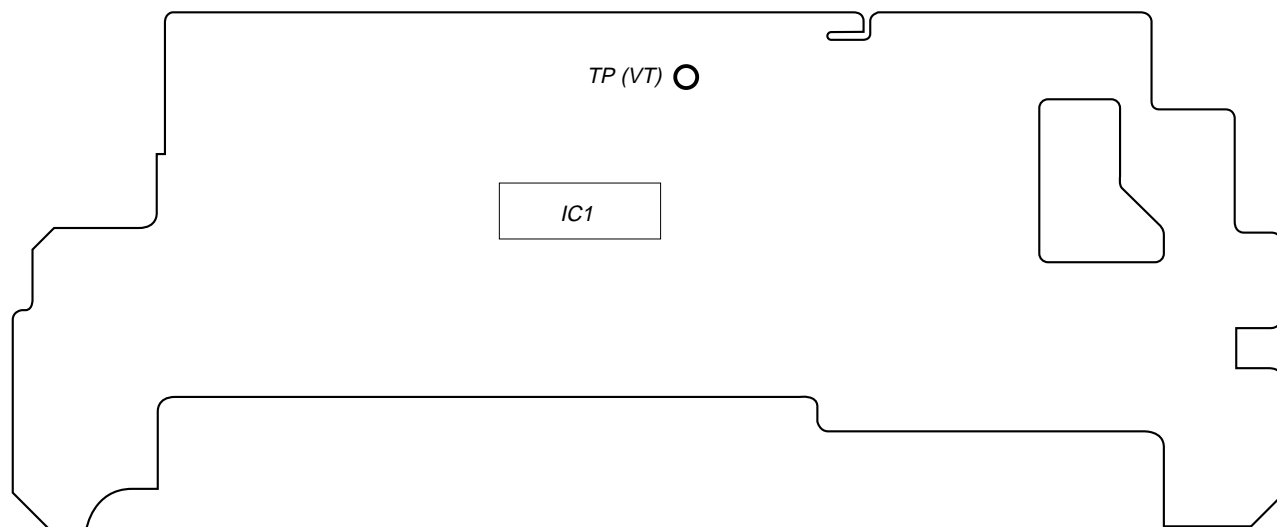

SECTION 4
DIAGRAMS

4-1. BLOCK DIAGRAM

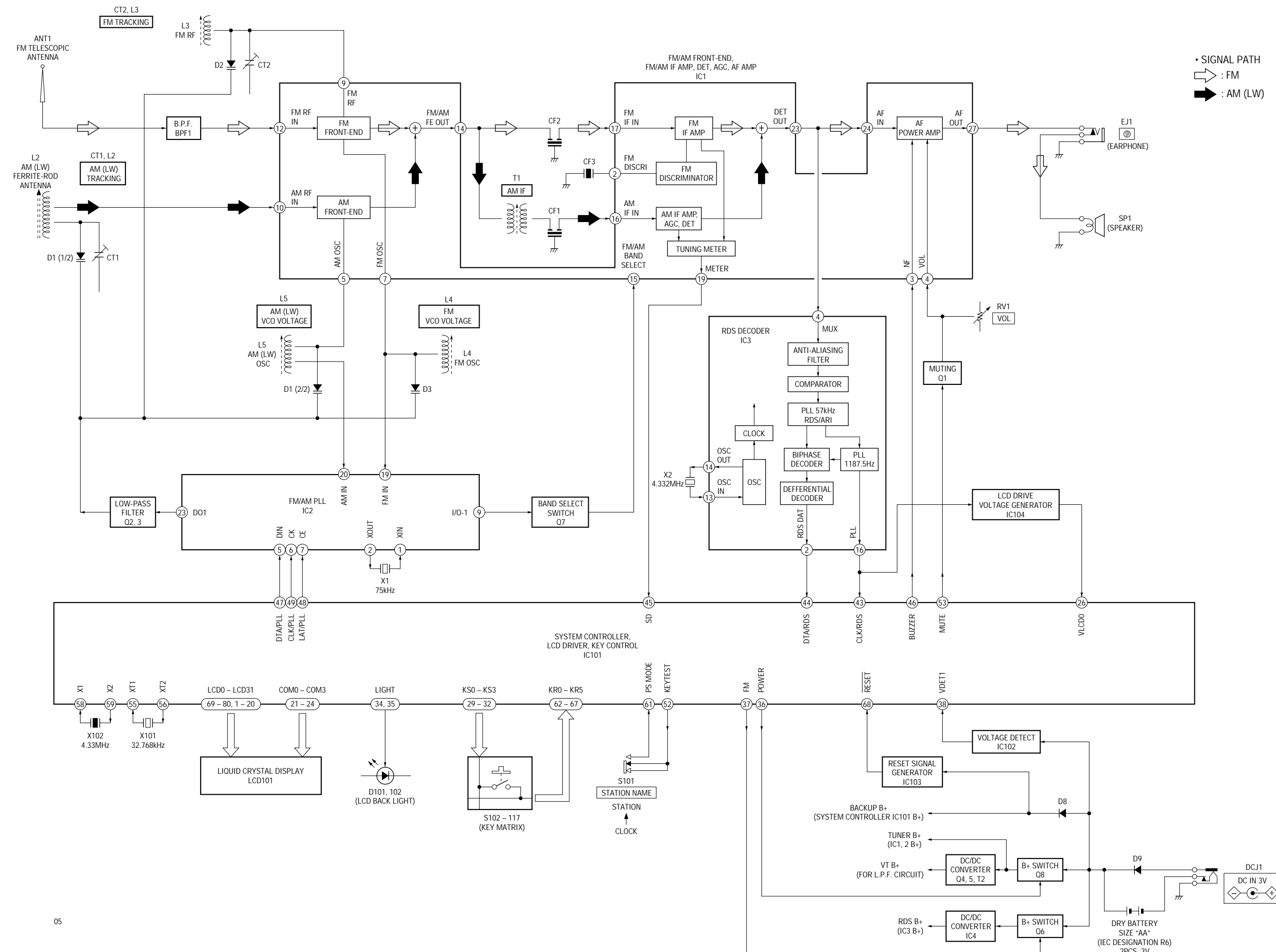

4-2. NOTE FOR PRINTED WIRING BOARDS AND SCHEMATIC DIAGRAMS

Note on Printed Wiring Board:

- : parts extracted from the component side.
- : parts extracted from the conductor side.
- ⊕ : indicates side identified with part number.
- : Through hole.
- △ : internal component.
- ⊙ : internal component.
- ▨ : Pattern from the side which enables seeing. (The other layers' patterns are not indicated.)

Caution:
 Pattern face side: Parts on the pattern face side seen from (Conductor Side) the pattern face are indicated.
 Parts face side: Parts on the parts face side seen from (Component Side) the parts face are indicated.

Note on Schematic Diagram:

- All capacitors are in μF unless otherwise noted. pF : μpF 50 WV or less are not indicated except for electrolytics and tantalums.
- All resistors are in Ω and $1/4\text{W}$ or less unless otherwise specified.
- △ : internal component.
- : panel designation.
- ⊕ : B+ Line.
- ▨ : adjustment for repair.
- Power voltage is dc 3 V and fed with regulated dc power supply from battery terminal.
- Voltages and waveforms are dc with respect to ground under no-signal (detuned) conditions.
- no mark : FM
- () : AM (LW)
- * : Impossible to measure
- Voltages are taken with a VOM (Input impedance 10 M Ω). Voltage variations may be noted due to normal production tolerances.
- Waveforms are taken with an oscilloscope. Voltage variations may be noted due to normal production tolerances.
- Circled numbers refer to waveforms.
- Signal path.
- : FM
- ⬤ : AM (LW)

• SIGNAL PATH
 ○ : FM
 ⬤ : AM (LW)

4-5. SCHEMATIC DIAGRAM • See page 25 for Waveforms. • See page 26 for IC Block Diagrams.

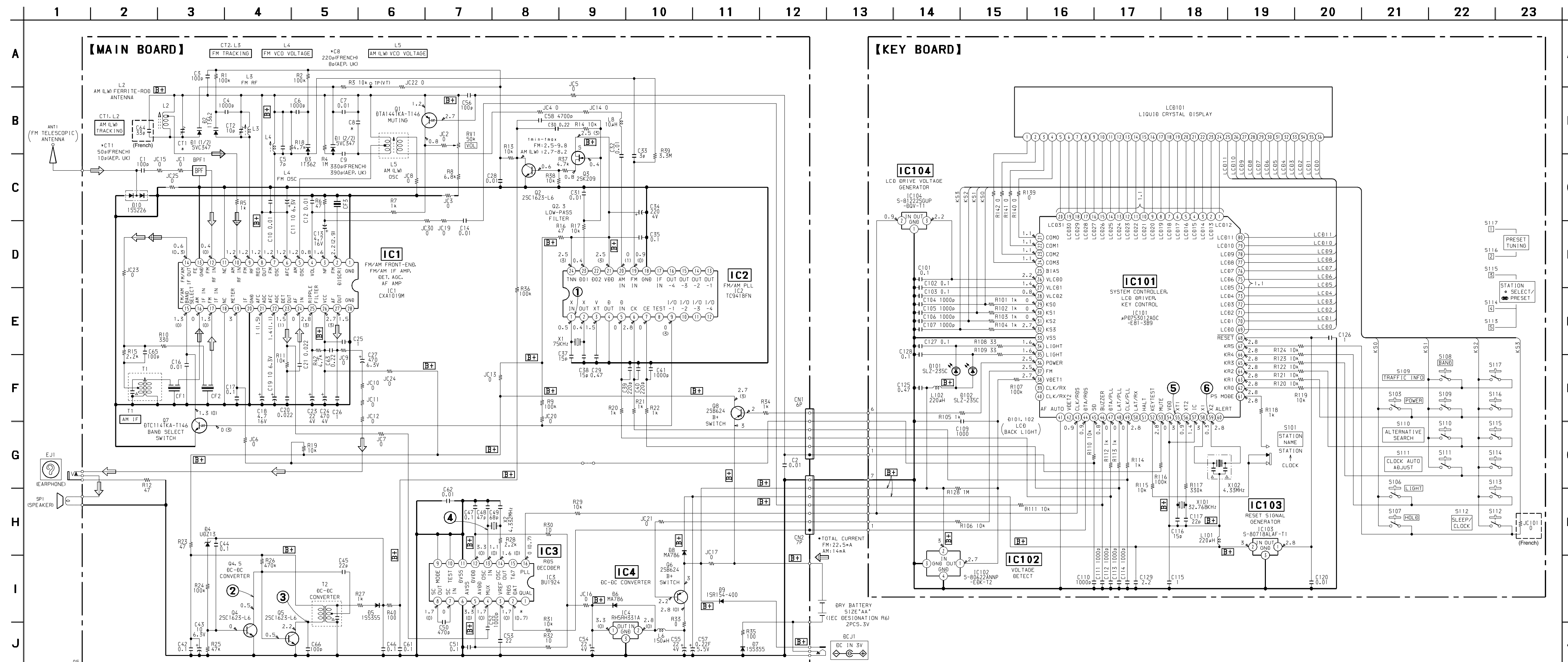

• Waveforms
– MAIN Board –

① IC2 ① (X IN)
400 mV/DIV, 5 μ s/DIV

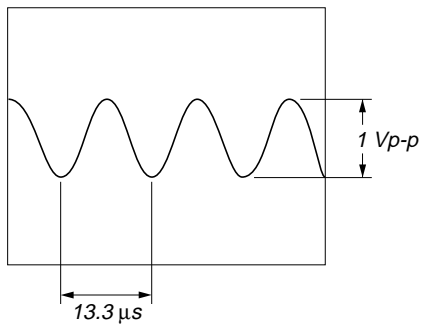

② Q4 (COLLECTOR)
100 mV/DIV, 200 ns/DIV

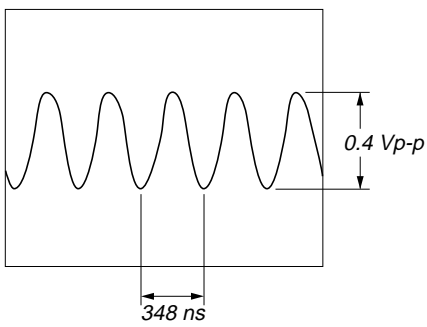

③ Q5 (COLLECTOR)
1 V/DIV, 200 ns/DIV

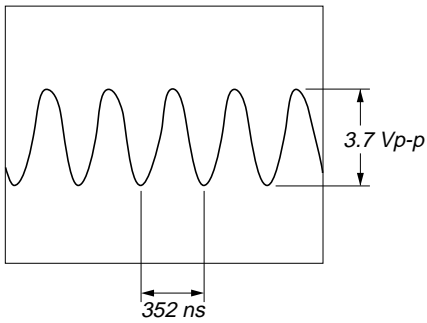

④ IC3 ⑬ (OSC IN)
400 mV/DIV, 100 ns/DIV

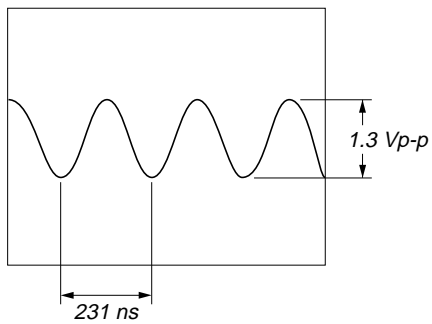

– KEY Board –

⑤ IC101 ⑤⑤ (XT1)
500 mV/DIV, 20 μ s/DIV

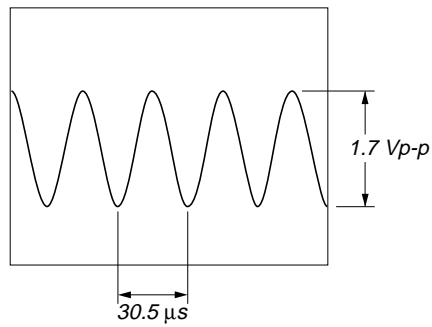

⑥ IC101 ⑥⑨ (X2)
1 V/DIV, 100 ns/DIV

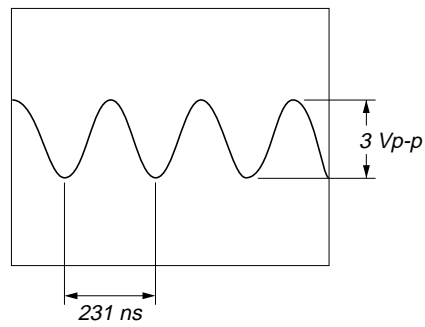

• IC Block Diagrams
 – MAIN Board –

IC1 CXA1019M-T6

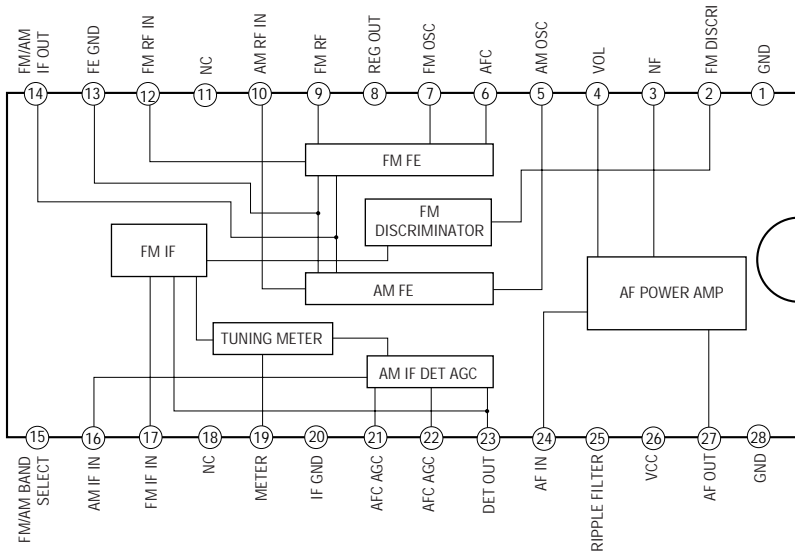

IC2 TC9418FN-EL

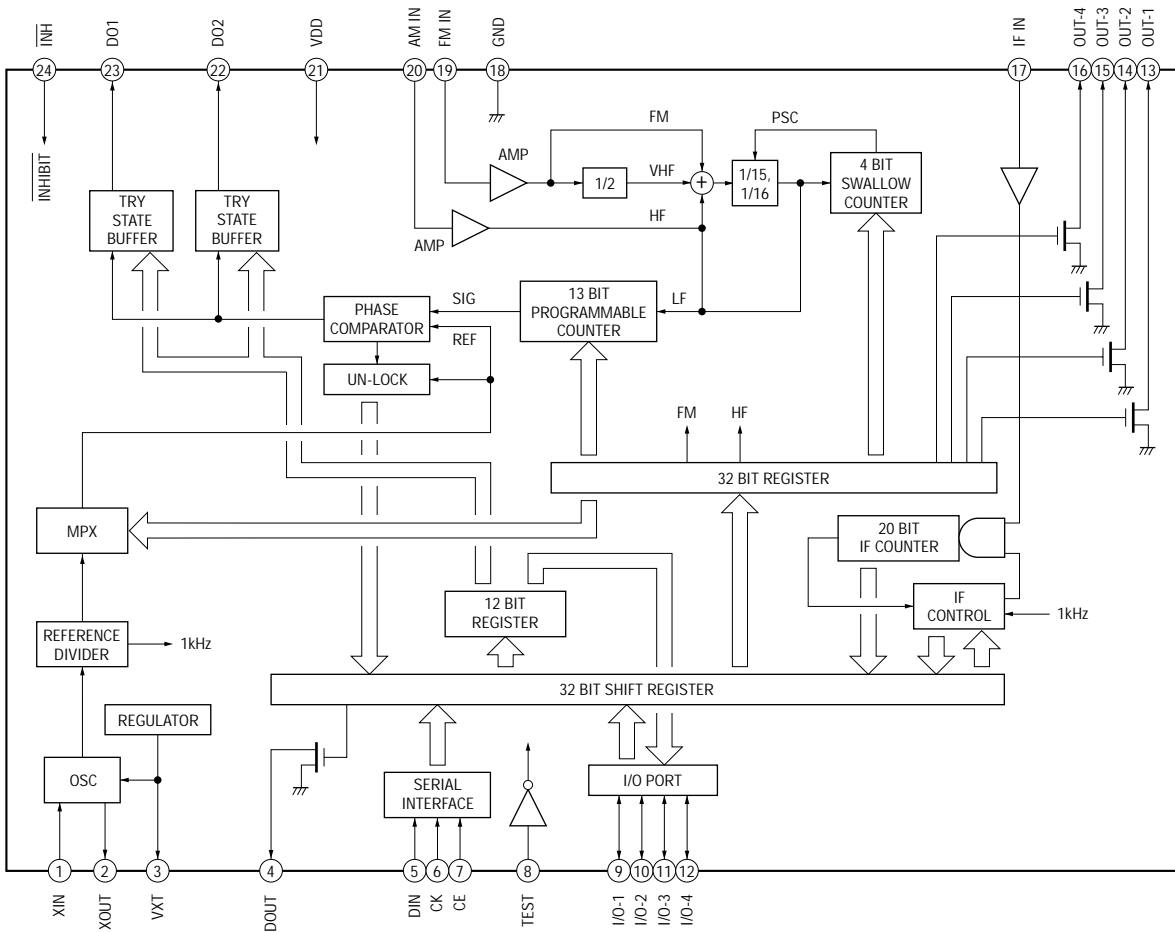

IC3 BU1924F

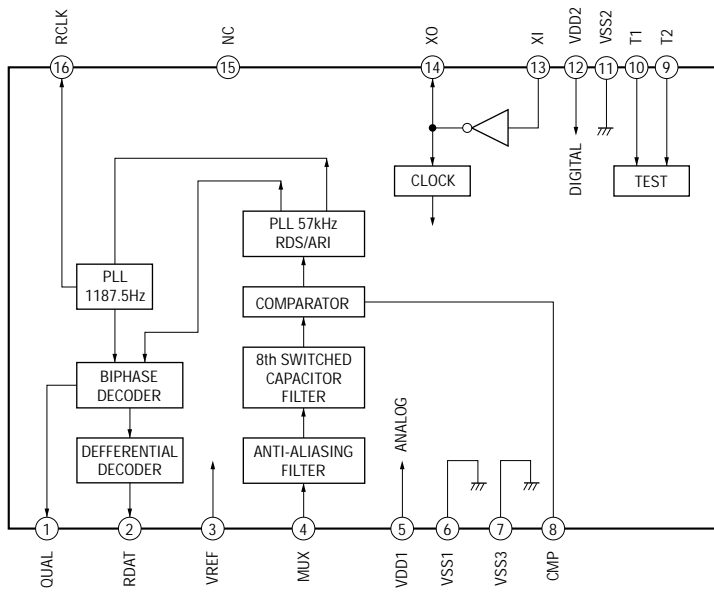

4-6. IC PIN FUNCTION DESCRIPTION

• KEY BOARD IC101 μ PD753012AGC-E81-3B9 (SYSTEM CONTROLLER, LCD DRIVER, KEY CONTROL)

Pin No.	Pin Name	I/O	Description
1 to 20	LCD12 to LCD31	O	Segment drive signal output to the liquid crystal display (LCD101)
21 to 24	COM0 to COM3	O	Common drive signal output to the liquid crystal display (LCD101)
25	BIAS	O	Liquid crystal display drive bias control output terminal Not used (open)
26	VLCD0	I	Develop liquid crystal display drive voltage input terminal
27, 28	VLCD1, VLCD2	I	Terminal for doubler circuit capacitor connection to develop liquid crystal display drive voltage
29 to 32	KS0 to KS3	O	Key scan signal output of the key matrix (S102 to S117)
33	VSS	—	Ground terminal
34, 35	LIGHT	O	Liquid crystal display back light LED drive signal output terminal “L”: back light on
36	POWER	O	PLL low-pass filter power supply on/off control signal output terminal “L”: power on
37	FM	O	RDS decode circuit power supply on/off control signal output terminal “L”: power on
38	VDET1	I	Battery voltage detect signal input terminal “L” is input at low voltage
39	CLK/RX	O	Clock signal output for the receive level control Not used (open)
40	DTA/RX	O	Data output for the receive level control Not used (open)
41	AF AUTO	I	AF mode selection signal input terminal “L”: manual mode, “H”: auto mode Fixed at “L” in this set
42	TEST	I	Test mode input terminal “L”: test mode Not used (open)
43	CLK/RDS	I	Serial data transfer clock signal input from the RDS decoder (IC3)
44	DTA/RDS	I	Serial data input from the RDS decoder (IC3)
45	SD	I	Station detector detect input from the CXA1019M (IC1) Stop level for SEEK, BTM, etc. is determined SD is present at input of “L”
46	BUZZER	O	Beep sound drive signal output to the CXA1019M (IC1)
47	DTA/PLL	O	Serial data output to the FM/AM PLL (IC2)
48	LAT/PLL	O	Serial data latch pulse signal output to the FM/AM PLL (IC2)
49	CLK/PLL	O	Serial data transfer clock signal output to the FM/AM PLL (IC2)
50	LAT/RX	O	Latch signal output for the receive level control Not used (open)
51	HALT	O	“H” is output at halt mode Not used (open)
52	KEYTEST	O	“L” is output at test mode
53	MUTE	O	Muting on/off control signal output terminal “L”: muting on
54	VDD	—	Power supply terminal (+3V)
55	XT1	I	Main system clock input terminal (4.332 MHz)
56	XT2	O	Main system clock output terminal (4.332 MHz)
57	IC	—	Connected to power supply (+3V)
58	X1	I	Sub system clock input terminal (32.768 kHz)
59	X2	O	Sub system clock output terminal (32.768 kHz)
60	SFT CLK	O	Alert signal output for the shift clock circuit “L”: on, “H”: off Not used (open)
61	PS MODE	I	Station name switch (S101) input terminal “L”: station, “H”: clock
62 to 67	KR0 to KR5	I	Key return signal input of the key matrix (S102 to S117)
68	$\overline{\text{RESET}}$	I	System reset signal input from the reset signal generator (IC103) “L”: reset “L” is input for several 100 msec after power on, then it changes to “H”
69 to 80	LCD0 to LCD11	O	Segment drive signal output to the liquid crystal display (LCD101)

SECTION 5 EXPLODED VIEW

NOTE:

- -XX and -X mean standardized parts, so they may have some difference from the original one.
- Color Indication of Appearance Parts
Example:
KNOB, BALANCE (WHITE) . . . (RED)
 ↑ ↑
 Parts Color Cabinet's Color

- Items marked “*” are not stocked since they are seldom required for routine service. Some delay should be anticipated when ordering these items.
- The mechanical parts with no reference number in the exploded views are not supplied.
- Accessories and packing materials are given in the last of the electrical parts list.

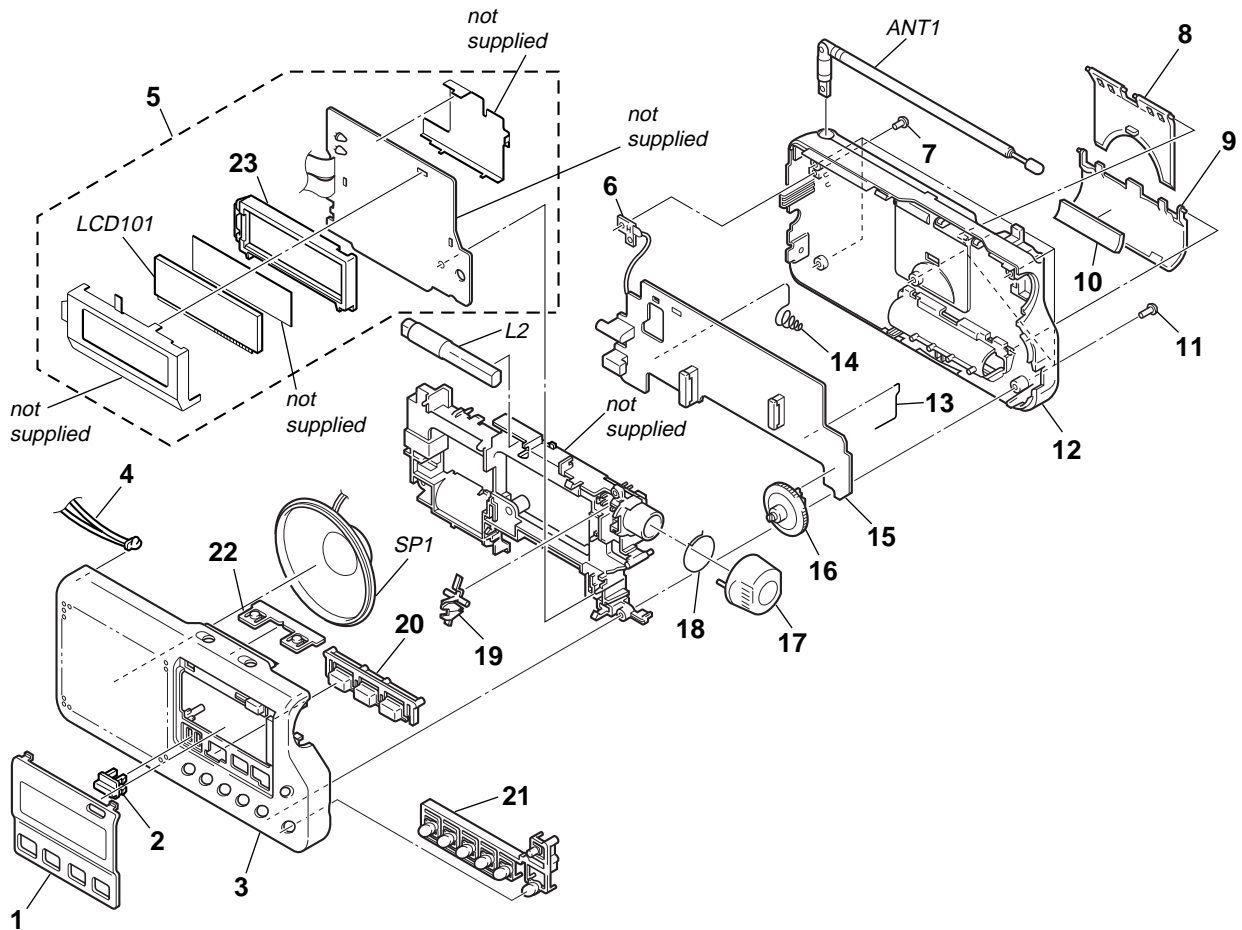

Ref. No.	Part No.	Description	Remark	Ref. No.	Part No.	Description	Remark
1	3-027-772-01	PANEL, FRONT		* 15	A-3663-154-A	MAIN BOARD, COMPLETE (AEP, UK)	
2	3-027-774-01	KNOB (RDS)		16	3-027-778-01	KNOB (VOL)	
3	3-027-770-01	CABINET (FRONT)(AEP, UK)		17	3-027-777-01	KNOB (JOG)	
3	3-027-770-11	CABINET (FRONT)(French)		18	3-027-787-01	SPRING, RING	
4	3-923-688-01	STRAP, HAND		19	3-027-780-01	ARM (JOG)	
* 5	A-3683-020-A	KEY PC BOARD ASSY (French)		20	3-027-773-01	BUTTON (RDS)	
* 5	A-3683-021-A	KEY PC BOARD ASSY (AEP, UK)		21	3-027-775-01	BUTTON (PRESET)	
6	3-027-790-01	PLATE, ANT CONTACT		22	3-027-776-01	BUTTON (HOLD)	
7	3-370-475-01	SCREW (NYLOCK +B 3X6)		23	3-027-781-01	PLATE, LIGHT GUIDE	
8	3-380-918-21	STAND		ANT1	1-501-362-11	ANTENNA, TELESCOPIC (FM)	
9	3-027-784-01	LID, BATTERY CASE		L2	1-754-030-11	ANTENNA, FERRITE-ROD (LW)(AEP, UK)	
10	3-028-720-01	CUSHION (BATTERY CASELID)		L2	1-754-031-11	ANTENNA, FERRITE-ROD (AM)(French)	
11	7-685-107-19	SCREW +P 2X12 TYPE2 NON-SLIT		LCD101	1-803-331-11	DISPLAY PANEL, LIQUID CRYSTAL	
12	3-027-771-01	CABINET (REAR)		SP1	1-504-748-21	SPEAKER (6.6CM)	
13	3-027-788-01	TERMINAL (+), BATTERY					
14	3-027-789-01	TERMINAL (-), BATTERY					
* 15	A-3663-149-A	MAIN BOARD, COMPLETE (French)					

SECTION 6 ELECTRICAL PARTS LIST

NOTE:

- Due to standardization, replacements in the parts list may be different from the parts specified in the diagrams or the components used on the set.
- -XX and -X mean standardized parts, so they may have some difference from the original one.
- RESISTORS
All resistors are in ohms.
METAL: Metal-film resistor.
METAL OXIDE: Metal oxide-film resistor.
F: nonflammable

- Items marked “**” are not stocked since they are seldom required for routine service. Some delay should be anticipated when ordering these items.
- SEMICONDUCTORS
In each case, u: μ , for example:
uA. . : μ A. . uPA. . : μ PA. .
uPB. . : μ PB. . uPC. . : μ PC. .
uPD. . : μ PD. .
- CAPACITORS
uF: μ F
- COILS
uH: μ H

When indicating parts by reference number, please include the board.

Ref. No.	Part No.	Description	Remark	Ref. No.	Part No.	Description	Remark
*	A-3663-149-A	MAIN BOARD, COMPLETE (French)		C34	1-124-434-00	ELECT 220uF	20% 4V
*	A-3663-154-A	MAIN BOARD, COMPLETE (AEP, UK)		C35	1-163-038-00	CERAMIC CHIP 0.1uF	25V

		< BAND PASS FILTER >		C37	1-163-231-11	CERAMIC CHIP 15PF	5% 50V
BPF1	1-236-711-21	FILTER, BAND PASS		C38	1-163-231-11	CERAMIC CHIP 15PF	5% 50V
		< CAPACITOR >		C39	1-163-125-00	CERAMIC CHIP 220PF	5% 50V
C1	1-163-251-11	CERAMIC CHIP 100PF	5% 50V	C40	1-163-125-00	CERAMIC CHIP 220PF	5% 50V
C2	1-163-021-91	CERAMIC CHIP 0.01uF	10% 50V	C41	1-163-009-11	CERAMIC CHIP 0.001uF	10% 50V
C3	1-163-251-11	CERAMIC CHIP 100PF	5% 50V	C42	1-164-004-11	CERAMIC CHIP 0.1uF	10% 25V
C4	1-163-141-00	CERAMIC CHIP 0.001uF	5% 50V	C43	1-126-157-11	ELECT 10uF	20% 16V
C5	1-163-224-11	CERAMIC CHIP 7PF	0.25PF 50V	C44	1-164-004-11	CERAMIC CHIP 0.1uF	10% 25V
C6	1-163-141-00	CERAMIC CHIP 0.001uF	5% 50V	C45	1-163-235-11	CERAMIC CHIP 22PF	5% 50V
C7	1-163-021-91	CERAMIC CHIP 0.01uF	10% 50V	C46	1-164-004-11	CERAMIC CHIP 0.1uF	10% 25V
C8	1-163-125-00	CERAMIC CHIP 220PF	5% 50V	C47	1-163-038-00	CERAMIC CHIP 0.1uF	25V
C8	1-163-091-00	CERAMIC CHIP 8PF (AEP, UK)		C48	1-163-243-11	CERAMIC CHIP 47PF	5% 50V
C9	1-163-129-00	CERAMIC CHIP 330PF	5% 50V	C49	1-163-113-00	CERAMIC CHIP 68PF	5% 50V
			(French)	C50	1-163-133-00	CERAMIC CHIP 470PF	5% 50V
C9	1-163-131-00	CERAMIC CHIP 390PF	5% 50V	C51	1-163-038-00	CERAMIC CHIP 0.1uF	25V
			(AEP, UK)	C52	1-163-009-11	CERAMIC CHIP 0.001uF	10% 50V
C10	1-163-059-91	CERAMIC CHIP 0.01uF	10% 50V	C53	1-164-505-11	CERAMIC CHIP 2.2uF	16V
C11	1-126-157-11	ELECT 10uF	20% 16V	C54	1-104-847-11	TANTAL. CHIP 22uF	20% 4V
C12	1-163-021-11	CERAMIC CHIP 0.01uF	10% 50V	C55	1-124-430-00	ELECT 22uF	20% 4V
C13	1-124-259-11	ELECT 4.7uF	20% 16V	C56	1-163-251-11	CERAMIC CHIP 100PF	5% 50V
C14	1-163-021-11	CERAMIC CHIP 0.01uF	10% 50V	C57	1-104-905-11	CAPACITOR 0.22F	5.5V
C16	1-163-021-11	CERAMIC CHIP 0.01uF	10% 50V	C58	1-163-017-00	CERAMIC CHIP 0.0047uF	5% 50V
C17	1-163-038-00	CERAMIC CHIP 0.1uF	25V	C61	1-164-004-11	CERAMIC CHIP 0.1uF	10% 25V
C18	1-124-259-11	ELECT 4.7uF	20% 16V	C62	1-163-021-11	CERAMIC CHIP 0.01uF	10% 50V
C19	1-126-157-11	ELECT 10uF	20% 16V	C63	1-164-489-11	CERAMIC CHIP 0.22uF	10% 16V
C20	1-163-037-11	CERAMIC CHIP 0.022uF	10% 25V	C64	1-163-239-11	CERAMIC CHIP 33PF	5% 50V
C21	1-163-037-11	CERAMIC CHIP 0.022uF	10% 25V				(French)
C23	1-124-430-00	ELECT 22uF	20% 4V	C65	1-163-251-11	CERAMIC CHIP 100PF	5% 50V
C24	1-126-518-11	ELECT 470uF	20% 4V	C66	1-163-251-11	CERAMIC CHIP 100PF	5% 50V
C25	1-164-346-11	CERAMIC CHIP 1uF	16V			< FILTER >	
C26	1-164-346-11	CERAMIC CHIP 1uF	16V	CF1	1-578-677-21	FILTER, CRYSTAL (French)	
C27	1-126-935-11	ELECT 470uF	20% 6.3V	* CF1	1-577-319-11	FILTER, CERAMIC (AEP, UK)	
C28	1-163-021-11	CERAMIC CHIP 0.01uF	10% 50V	CF2	1-579-632-41	FILTER, CERAMIC	
C29	1-164-005-11	CERAMIC CHIP 0.47uF	25V	CF3	1-579-632-41	FILTER, CERAMIC	
C30	1-164-489-11	CERAMIC CHIP 0.22uF	10% 16V			< CONNECTOR >	
C31	1-163-021-11	CERAMIC CHIP 0.01uF	10% 50V	* CN1	1-568-272-11	SOCKET, CONNECTOR 6P	
C32	1-163-021-11	CERAMIC CHIP 0.01uF	10% 50V	* CN2	1-568-273-11	SOCKET, CONNECTOR 7P	
C33	1-163-220-11	CERAMIC CHIP 3PF	0.25PF 50V				

Ref. No.	Part No.	Description	Remark	Ref. No.	Part No.	Description	Remark
		< TRIMMER >		L5	1-415-930-11	COIL(OSC) (French)	
CT1	1-141-444-11	CAP, CERAMIC TRIMMER 50PF (French)		L5	1-406-485-11	COIL(OSC) (AEP, UK)	
CT1	1-141-304-21	CAP, TRIMMER 10PF (AEP, UK)		L6	1-414-405-11	INDUCTOR 150uH	
CT2	1-141-304-21	CAP, TRIMMER 10PF		L8	1-412-006-31	INDUCTOR CHIP 10uH	
		< DIODE >				< TRANSISTOR >	
D1	8-719-072-59	DIODE SVC347S-TL		Q1	8-729-027-39	TRANSISTOR DTA144TKA-T146	
D2	8-713-100-11	DIODE 1T362-04-T8B		Q2	8-729-120-28	TRANSISTOR 2SC1623-T1L6	
D3	8-713-100-11	DIODE 1T362-04-T8B		Q3	8-729-220-93	FET 2SK209G-TE85L	
D4	8-719-977-40	DIODE UDZ-TE-17-13B		Q4	8-729-120-28	TRANSISTOR 2SC1623-T1L6	
D5	8-719-988-61	DIODE 1SS355TE-17		Q5	8-729-120-28	TRANSISTOR 2SC1623-T1L6	
D6	8-719-026-23	DIODE MA786-TX		Q6	8-729-141-48	TRANSISTOR 2SB624-T1BV4	
D7	8-719-988-61	DIODE 1SS355TE-17		Q7	8-729-027-44	TRANSISTOR DTC114TKA-T146	
D8	8-719-026-23	DIODE MA786-TX		Q8	8-729-141-48	TRANSISTOR 2SB624-T1BV4	
D9	8-719-053-18	DIODE 1SR154-400TE-25				< RESISTOR >	
D10	8-719-800-76	DIODE 1SS226-TE85L		R1	1-216-097-00	RES,CHIP 100K 5%	1/10W
		< JACK >		R2	1-216-097-00	RES,CHIP 100K 5%	1/10W
DCJ1	1-764-799-11	JACK, EXTERNAL POWER (DC IN 3V)		R3	1-216-073-00	METAL CHIP 10K 5%	1/10W
EJ1	1-563-836-21	JACK (Ⓢ)		R4	1-216-121-00	RES,CHIP 1M 5%	1/10W
		< IC >		R5	1-216-049-11	RES,CHIP 1K 5%	1/10W
IC1	8-752-050-16	IC CXA1019M-T6		R6	1-216-017-00	RES,CHIP 47 5%	1/10W
IC2	8-759-362-24	IC TC9418FN-EL		R7	1-216-198-00	RES,CHIP 1K 5%	1/8W
IC3	8-759-560-51	IC BU1924F		R8	1-216-069-00	METAL CHIP 6.8K 5%	1/10W
IC4	8-759-434-03	IC RH5RH331A-T1		R9	1-216-097-00	RES,CHIP 100K 5%	1/10W
		< SHORT >		R10	1-216-037-00	METAL CHIP 330 5%	1/10W
JC1	1-216-296-00	SHORT 0		R11	1-216-073-00	METAL CHIP 10K 5%	1/10W
JC2	1-216-295-00	SHORT 0		R12	1-216-017-00	RES,CHIP 47 5%	1/10W
JC3	1-216-296-00	SHORT 0		R13	1-216-073-00	METAL CHIP 10K 5%	1/10W
JC4	1-216-296-00	SHORT 0		R14	1-216-073-00	METAL CHIP 10K 5%	1/10W
JC5	1-216-296-00	SHORT 0		R15	1-216-057-00	METAL CHIP 2.2K 5%	1/10W
JC6	1-216-295-00	SHORT 0		R16	1-216-017-00	RES,CHIP 47 5%	1/10W
JC7	1-216-296-00	SHORT 0		R17	1-216-073-00	METAL CHIP 10K 5%	1/10W
JC8	1-216-295-00	SHORT 0		R18	1-216-065-00	RES,CHIP 4.7K 5%	1/10W
JC9	1-216-296-00	SHORT 0		R19	1-216-073-00	METAL CHIP 10K 5%	1/10W
JC10	1-216-296-00	SHORT 0		R20	1-216-049-91	RES,CHIP 1K 5%	1/10W
JC11	1-216-296-00	SHORT 0		R21	1-216-049-11	RES,CHIP 1K 5%	1/10W
JC12	1-216-296-00	SHORT 0		R22	1-216-198-00	RES,CHIP 1K 5%	1/8W
JC13	1-216-295-00	SHORT 0		R23	1-216-043-91	RES,CHIP 560 5%	1/10W
JC14	1-216-296-00	SHORT 0		R24	1-216-097-00	RES,CHIP 100K 5%	1/10W
JC15	1-216-296-00	SHORT 0		R25	1-216-089-00	RES,CHIP 47K 5%	1/10W
JC16	1-216-296-00	SHORT 0		R26	1-216-113-00	METAL CHIP 470K 5%	1/10W
JC17	1-216-296-00	SHORT 0		R27	1-216-049-11	RES,CHIP 1K 5%	1/10W
JC19	1-216-296-00	SHORT 0		R28	1-216-057-00	METAL CHIP 2.2K 5%	1/10W
JC20	1-216-296-00	SHORT 0		R29	1-216-073-00	METAL CHIP 10K 5%	1/10W
JC21	1-216-295-00	SHORT 0		R30	1-216-001-00	METAL CHIP 10 5%	1/10W
JC22	1-216-296-00	SHORT 0		R31	1-216-073-00	METAL CHIP 10K 5%	1/10W
JC23	1-216-295-00	SHORT 0		R32	1-216-001-00	METAL CHIP 10 5%	1/10W
JC24	1-216-295-00	SHORT 0		R33	1-216-295-00	SHORT 0	
JC30	1-216-295-00	SHORT 0		R34	1-216-049-11	RES,CHIP 1K 5%	1/10W
		< COIL >		R35	1-216-025-00	RES,CHIP 100 5%	1/10W
L2	1-754-030-11	ANTENNA, FERRITE-ROD (LW) (AEP, UK)		R36	1-216-097-00	RES,CHIP 100K 5%	1/10W
L2	1-754-031-11	ANTENNA, FERRITE-ROD (AM) (French)		R37	1-216-065-00	RES,CHIP 4.7K 5%	1/10W
L3	1-406-545-11	COIL, AIR-CORE		R38	1-216-073-00	METAL CHIP 10K 5%	1/10W
L4	1-406-546-11	COIL, AIR-CORE		R39	1-216-133-00	METAL CHIP 3.3M 5%	1/10W
				R40	1-216-025-00	RES,CHIP 100 5%	1/10W
				R42	1-216-065-00	RES,CHIP 4.7K 5%	1/10W

MAIN	KEY
-------------	------------

Ref. No.	Part No.	Description	Remark	Ref. No.	Part No.	Description	Remark
		< VARIABLE RESISTOR >				< COIL >	
RV1	1-225-441-41	RES, VAR, CARBON 50K		L101	1-414-406-11	INDUCTOR 220uH	
		< TRANSFORMER >		L102	1-414-406-11	INDUCTOR 220uH	
T1	1-404-790-11	TRANSFORMER, IF				< LIQUID CRYSTAL DISPLAY >	
T2	1-449-138-11	TRANSFORMER, DC-DC CONVERTER		LCD101	1-803-331-11	DISPLAY PANEL, LIQUID CRYSTAL	
		< VIBRATOR >				< RESISTOR >	
X1	1-767-517-11	VIBRATOR, CRYSTAL (75kHz)		R101	1-216-821-11	METAL CHIP 1K 5%	1/16W
X2	1-579-900-21	VIBRATOR, CRYSTAL (4.332MHz)		R102	1-216-821-11	METAL CHIP 1K 5%	1/16W
*****				R103	1-216-821-11	METAL CHIP 1K 5%	1/16W
*	A-3683-020-A	KEY BOARD, COMPLETE (French)		R104	1-216-821-11	METAL CHIP 1K 5%	1/16W
*	A-3683-021-A	KEY BOARD, COMPLETE (AEP, UK)		R105	1-216-049-11	RES,CHIP 1K 5%	1/10W
		*****		R106	1-216-073-00	METAL CHIP 10K 5%	1/10W
	3-027-781-01	PLATE,LIGHT GUID		R107	1-216-097-00	RES,CHIP 100K 5%	1/10W
		< CAPACITOR >		R108	1-216-013-00	METAL CHIP 33 5%	1/10W
C101	1-163-038-00	CERAMIC CHIP 0.1uF	25V	R109	1-216-013-00	METAL CHIP 33 5%	1/10W
C102	1-163-038-00	CERAMIC CHIP 0.1uF	25V	R110	1-216-833-11	METAL CHIP 10K 5%	1/16W
C103	1-163-038-00	CERAMIC CHIP 0.1uF	25V	R111	1-216-833-11	METAL CHIP 10K 5%	1/16W
C104	1-163-009-11	CERAMIC CHIP 0.001uF 10%	50V	R112	1-216-821-11	METAL CHIP 1K 5%	1/16W
C105	1-163-009-11	CERAMIC CHIP 0.001uF 10%	50V	R113	1-216-821-11	METAL CHIP 1K 5%	1/16W
C106	1-163-009-11	CERAMIC CHIP 0.001uF 10%	50V	R114	1-216-821-11	METAL CHIP 1K 5%	1/16W
C107	1-163-009-11	CERAMIC CHIP 0.001uF 10%	50V	R115	1-216-833-11	METAL CHIP 10K 5%	1/16W
C109	1-163-009-11	CERAMIC CHIP 0.001uF 10%	50V	R116	1-216-845-11	METAL CHIP 100K 5%	1/16W
C110	1-163-009-11	CERAMIC CHIP 0.001uF 10%	50V	R117	1-216-851-11	METAL CHIP 330K 5%	1/16W
C111	1-163-009-11	CERAMIC CHIP 0.001uF 10%	50V	R118	1-216-821-11	METAL CHIP 1K 5%	1/16W
C112	1-163-009-11	CERAMIC CHIP 0.001uF 10%	50V	R119	1-216-833-11	METAL CHIP 10K 5%	1/16W
C113	1-163-009-11	CERAMIC CHIP 0.001uF 10%	50V	R120	1-216-833-11	METAL CHIP 10K 5%	1/16W
C114	1-163-009-11	CERAMIC CHIP 0.001uF 10%	50V	R121	1-216-833-11	METAL CHIP 10K 5%	1/16W
C115	1-164-346-11	CERAMIC CHIP 1uF	16V	R122	1-216-833-11	METAL CHIP 10K 5%	1/16W
C116	1-163-231-11	CERAMIC CHIP 15PF 5%	50V	R123	1-216-833-11	METAL CHIP 10K 5%	1/16W
C117	1-163-235-11	CERAMIC CHIP 22PF 5%	50V	R124	1-216-833-11	METAL CHIP 10K 5%	1/16W
C120	1-163-021-91	CERAMIC CHIP 0.01uF 10%	50V	R128	1-216-121-00	RES,CHIP 1M 5%	1/10W
C125	1-164-005-11	CERAMIC CHIP 0.47uF	25V	R139	1-216-295-00	SHORT 0	
C126	1-164-346-11	CERAMIC CHIP 1uF	16V	R140	1-216-295-00	SHORT 0	
C127	1-164-004-11	CERAMIC CHIP 0.1uF 10%	25V	R141	1-216-295-00	SHORT 0	
C128	1-164-004-11	CERAMIC CHIP 0.1uF 10%	25V	R142	1-216-295-91	SHORT 0	
C129	1-164-505-11	CERAMIC CHIP 2.2uF	16V			< SWITCH >	
		< DIODE >		S101	1-553-510-00	SWITCH, SLIDE (STATION NAME)	
D101	8-719-047-42	LED SLZ-235C-16-T1 (LCD BACK LIGHT)		S103	1-762-233-11	SWITCH, KEYBOARD (POWER)	
D102	8-719-047-42	LED SLZ-235C-16-T1 (LCD BACK LIGHT)		S106	1-762-233-11	SWITCH, KEYBOARD (LIGHT)	
		< IC >		S107	1-572-499-11	SWITCH, TACTIL (HOLD)	
IC101	8-759-564-81	IC uPD753012AGC-E81-3B9		S108	1-762-233-11	SWITCH, KEYBOARD (BAND)	
IC102	8-759-575-75	IC S-80822ANNP-EDK-T2		S109	1-762-233-11	SWITCH, KEYBOARD (TRAFFIC INFO)	
IC103	8-759-521-02	IC S-80718AL-AF-T1		S110	1-762-233-11	SWITCH, KEYBOARD (ALTERNATIVE SEARCH)	
IC104	8-759-449-90	IC S-81222SGUP-DQV-T1		S111	1-762-233-11	SWITCH, KEYBOARD (CLOCK AUTO ADJUST)	
		< SHORT >		S112	1-572-499-11	SWITCH, TACTIL (SLEEP/CLOCK)	
JC101	1-216-864-11	METAL CHIP 0 5%	1/16W (French)	S113	1-762-233-11	SWITCH, KEYBOARD (5)	
				S114	1-762-233-11	SWITCH, KEYBOARD (4)	
				S115	1-762-233-11	SWITCH, KEYBOARD (3)	
				S116	1-762-233-11	SWITCH, KEYBOARD (2)	
				S117	1-762-233-11	SWITCH, KEYBOARD (1)	
						< VIBRATOR >	
				X101	1-567-098-41	VIBRATOR, CRYSTAL (32.768kHz)	

<u>Ref. No.</u>	<u>Part No.</u>	<u>Description</u>	<u>Remark</u>
X102	1-781-363-21	VIBRATOR, CERAMIC (4.33MHz)	

ACCESSORIES & PACKING MATERIALS

3-864-831-11	MANUAL, INSTRUCTION	(ENGLISH, FRENCH, GERMAN, DUTCH)	
3-864-831-21	MANUAL, INSTRUCTION	(ITALIAN, SPANISH, PORTGUESE, SWEDISH)	
3-864-831-31	MANUAL, INSTRUCTION	(FINNISH, DANISH)	

