

WM-FX673/FX877

SERVICE MANUAL

Ver 1.0 1999.03



Photo: WM-FX673

Canadian Model
AEP Model
UK Model
Australian Model
WM-FX673
E Model
WM-FX673/FX877
Chinese Model
Tourist Model
WM-FX877

Dolby noise reduction manufactured under license from Dolby Laboratories Licensing Corporation. "DOLBY" and the double-D symbol \square are trademarks of Dolby Laboratories Licensing Corporation.

Model Name Using Similar Mechanism	WM-EX670/EX672
Tape Transport Mechanism Type	MT-WMEX672-162

SPECIFICATIONS

Radio section

Frequency range

FM: 87.5–108 MHz
AM: 530–1,710 kHz (Canadian model)
531–1,602 kHz (Except Canadian model)

Tape section

Frequency response (Dolby NR off)

Playback: 40–15,000 Hz

Output

Headphones (⌚ REMOTE) jack
Load impedance 8–300 ohms

General

Power requirements

1.5 V
Rechargeable battery
One R6 (size AA) battery

Dimensions (w/h/d)

Approx. 108.9 x 77.7 x 23.9 mm
(4 $\frac{3}{8}$ x 3 $\frac{1}{8}$ x $\frac{3}{16}$ inches), incl.
projecting parts and controls

Mass

Approx. 145 g (5.2 oz)
Approx. 210 g (7.5 oz) incl.
rechargeable battery and a
cassette

Supplied accessories

Battery case (1)
Stereo headphones or Stereo
earphones with remote control
(1)
Battery charger (1)
AC plug adaptor (1) (except for
European, Australian, Saudi
Arabian, Chinese, Hong Kong,
U.S.A., Canadian, and Korean
model)
Rechargeable battery (NC-6WM,
1.2 V, 600 mAh, Ni-Cd) (1)
Rechargeable battery carrying case
(1)
Carrying pouch (1)

Design and specifications are subject
to change without notice.

Battery life (Approx. hours) (EIAJ*)

Sony alkaline LR6 (5G)

Tape playback	36
Radio reception	32

Rechargeable battery (NC-6WM)

Tape playback	10
Radio reception	10

Sony alkaline LR6 (5G) and Rechargeable NC-6WM

Tape playback	45
Radio reception	42

* Measured value by the standard of
EIAJ (Electronic Industries
Association of Japan). (Using a Sony
HF series cassette tape)

Note

- The battery life may shorten
depending on the operation of the
unit.

RADIO CASSETTE PLAYER

SONY®



TABLE OF CONTENTS

1. SERVICING NOTES	3
2. GENERAL	5
3. DISASSEMBLY	7
4. MECHANICAL ADJUSTMENTS	12
5. ELECTRICAL ADJUSTMENTS	12
6. DIAGRAMS	
6-1. Block Diagram – TUNER Section –	15
6-2. Block Diagram – MAIN Section –	17
6-3. Printed Wiring Board	19
6-4. Schematic Diagram	23
6-5. IC Pin Function Description	30
7. EXPLODED VIEWS	32
8. ELECTRICAL PARTS LIST	34

Flexible Circuit Board Repairing

- Keep the temperature of the soldering iron around 270 °C during repairing.
- Do not touch the soldering iron on the same conductor of the circuit board (within 3 times).
- Be careful not to apply force on the conductor when soldering or unsoldering.

Notes on chip component replacement

- Never reuse a disconnected chip component.
- Notice that the minus side of a tantalum capacitor may be damaged by heat.

SAFETY-RELATED COMPONENT WARNING!!

COMPONENTS IDENTIFIED BY MARK \triangle OR DOTTED LINE WITH MARK \triangle ON THE SCHEMATIC DIAGRAMS AND IN THE PARTS LIST ARE CRITICAL TO SAFE OPERATION. REPLACE THESE COMPONENTS WITH SONY PARTS WHOSE PART NUMBERS APPEAR AS SHOWN IN THIS MANUAL OR IN SUPPLEMENTS PUBLISHED BY SONY.

ATTENTION AU COMPOSANT AYANT RAPPORT À LA SÉCURITÉ!

LES COMPOSANTS IDENTIFIÉS PAR UNE MARQUE \triangle SUR LES DIAGRAMMES SCHÉMATIQUES ET LA LISTE DES PIÈCES SONT CRITIQUES POUR LA SÉCURITÉ DE FONCTIONNEMENT. NE REMPLACER CES COMPOSANTS QUE PAR DES PIÈCES SONY DONT LES NUMÉROS SONT DONNÉS DANS CE MANUEL OU DANS LES SUPPLÉMENTS PUBLIÉS PAR SONY.

SECTION 1 SERVICING NOTES

This set detects the rotation of the idler gear (A) (side S) using the PH1 (photo reflector). The PH1 is mounted on the MAIN board, therefore the idler gear (A) (side S) cannot be detected with the MAIN board removed. As a result, the motor (M601) cannot be controlled, causing malfunction.

Further, the DIRECTION switch (S1) is also mounted on the MAIN board, and with the board removed, the mechanism position cannot be detected and the operation is not changed over.

Therefore, when the voltage check is executed with the MAIN board removed, follow the procedure provided below.

1. Setting

- (1) Refer to "3. DISASSEMBLY", and remove the MAIN board.
- (2) Connect the MAIN board to the motor (M601) and the plunger (PM901) using jumper wires. These can be connected easily with the use of the extension tool (Part No. 1-769-143-11) (ten in one set).
- (3) Short the TAPE DETECT switch (S901-1) terminals and the ATS switch (S901-2) terminals.
- (4) Connect the AF oscillator to the Q15-1 (COLLECTOR) and the TP23 (GND).
- (5) Supply 1.3 V to the battery terminals using the regulated power supply.

2. Preset state

To set the PLAY, FF, REW modes, the preset state must be set.

- (1) Check that the slider (NR) and the DIRECTION switch (S1) are set to the center position. If not, set the preset state as follow.
- (2) Move the DIRECTION switch (S1) to the side, which the slider (NR) is facing.
- (3) The slider (NR) will move when the regulated power supply switch is set to OFF once and then set to ON. Move the DIRECTION switch (S1) according to this timing and set to the center position.

3. FF, REW modes

- (1) Check that the preset state is set.
- (2) Input the square wave or sine wave to the Q15-1 (COLLECTOR) and the TP23 (GND).
- (3) Press the **RADIO OFF** button (S3) to set the STOP mode.
- (4) Press the **FF AMS** button (S4) or the **REW AMS** button (S5).

4. PLAY mode

- (1) Check that the preset state is set.
- (2) Input the square wave or sine wave to the Q15-1 (COLLECTOR) and the TP23 (GND).
- (3) Press the **RADIO OFF** button (S3) to set the STOP mode.
- (4) Press the **REPEAT** button (S9) will move the slider (NR) once towards the side R and then to the side F. Move the DIRECTION switch (S1) according to this timing will set the PLAY mode (side F). Press the **REPEAT** button (S9) another time and move the DIRECTION switch (S1) according to the movement of the slider (NR) will set the PLAY (R mode).

Note 1: If the above fails, perform from preset again.

Note 2: Use the **REPEAT** (S9), **RADIO OFF** (S3), **FF AMS** (S4), and **REW AMS** (S5) buttons on the remote controller as much as possible. If no remote controller, do not touch the buttons with your hands, but using a stick with a round tip.

Note 3: When using headphones, the timing for move the DIRECTION switch (S1) can be determined from the beep sound.

– MAIN Board (side B) –

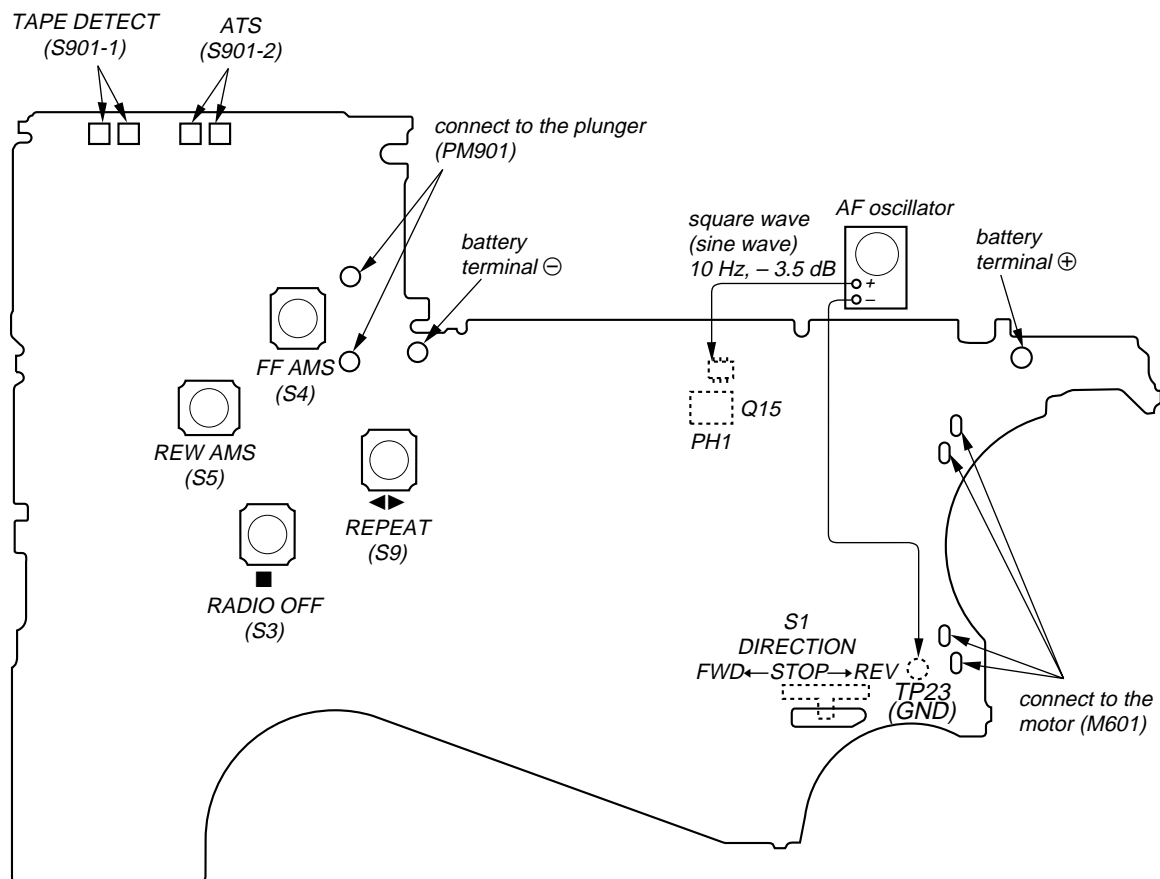

Slider (NR)

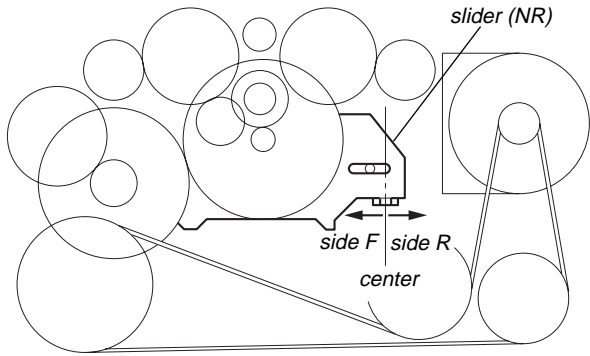

Rotation system

Rotation system during PLAY.

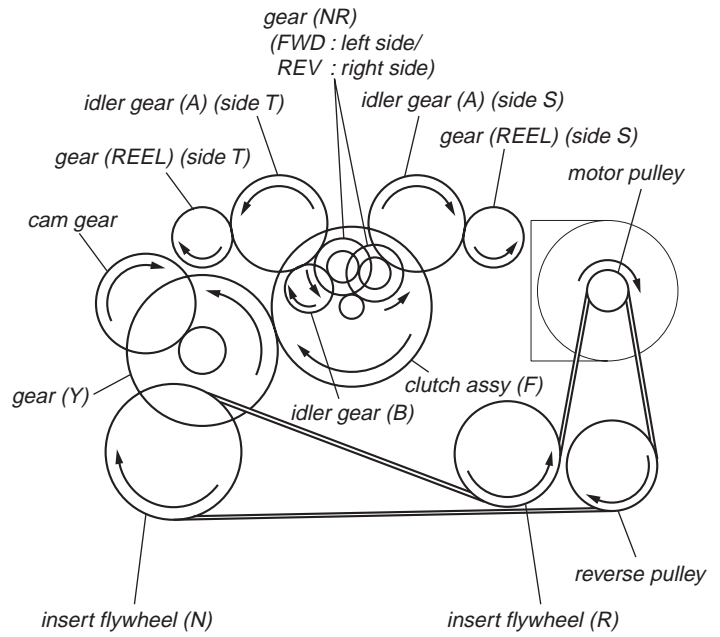

Rotation system during FF.

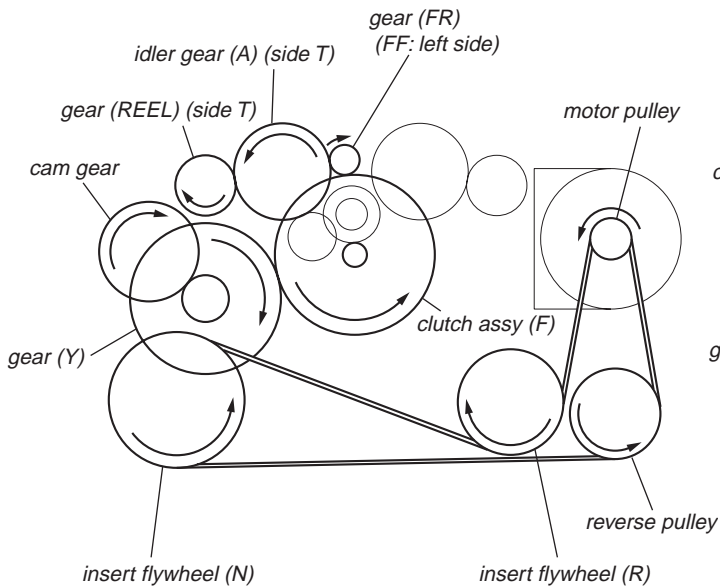

Rotation system during REW.

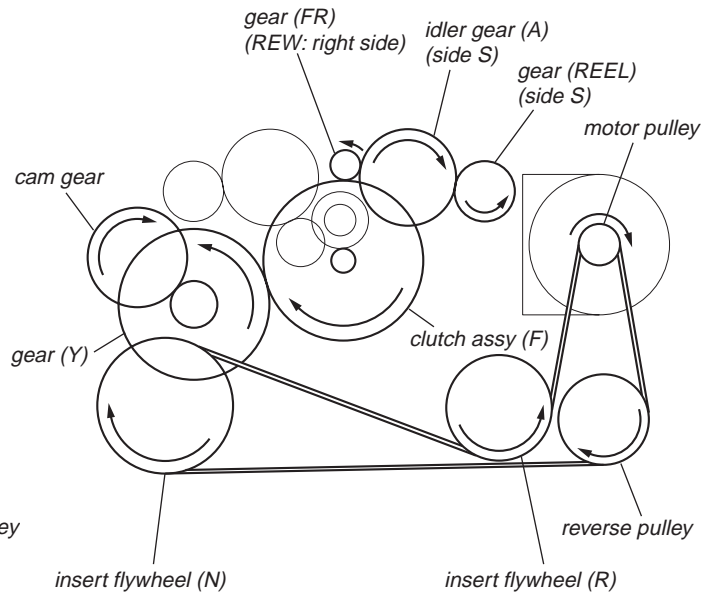

SECTION 2 GENERAL

This section is extracted from instruction manual.

A

(a)

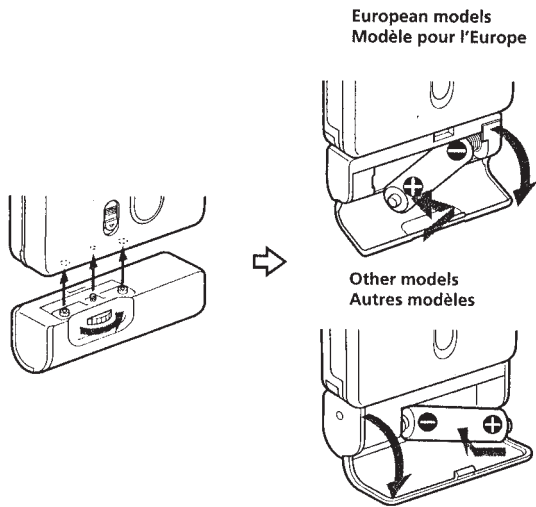

(b) U.K., Australian, and Hong Kong model
Modèle pour le Royaume-Uni, l'Australie et Hong-Kong

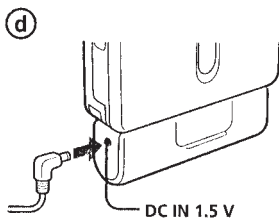
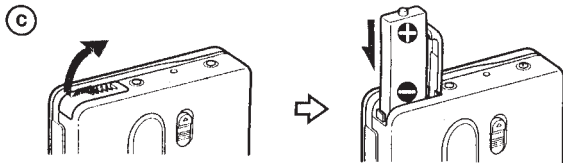

B (FX673)

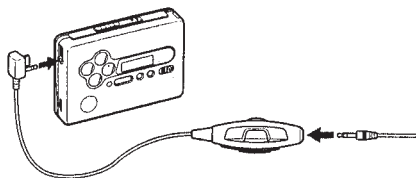

B (FX877)

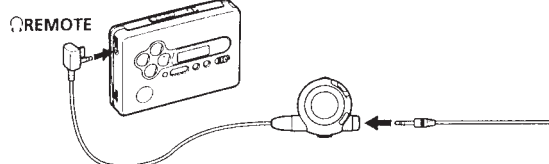

C (FX673)

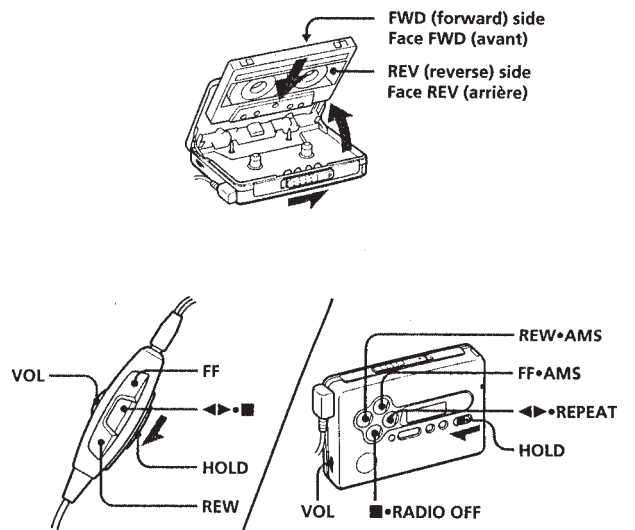

C (FX877)

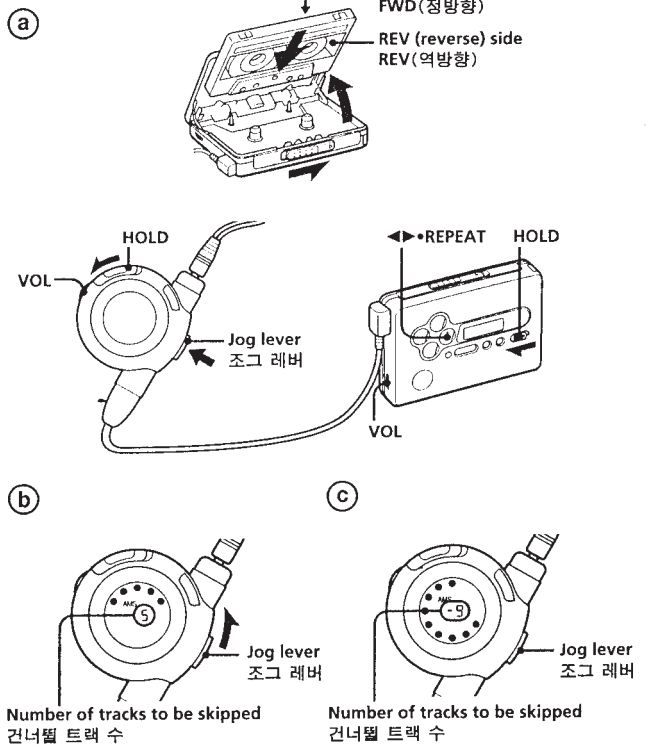

(d)

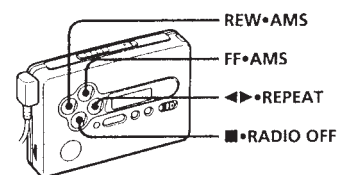

D (FX673)

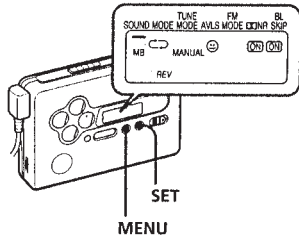

D (FX877)

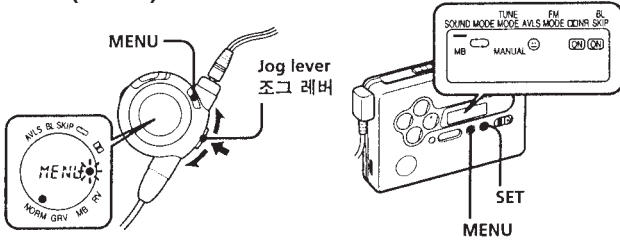

E (FX673)

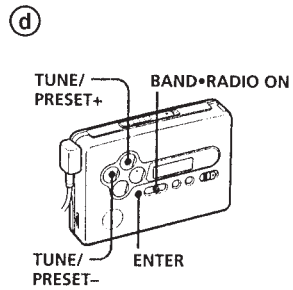
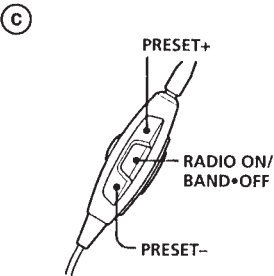
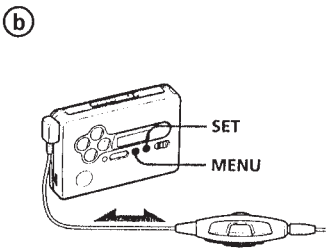
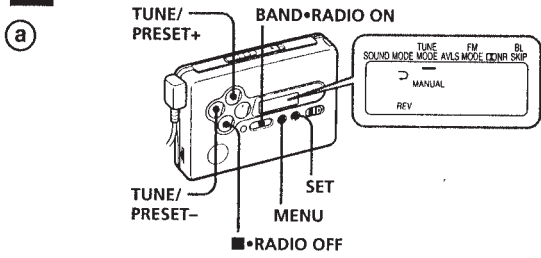

E (FX877)

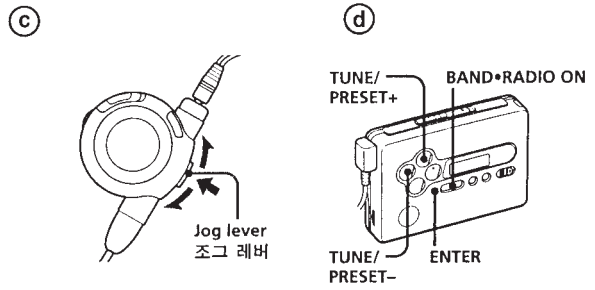
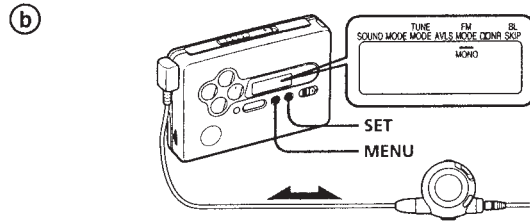
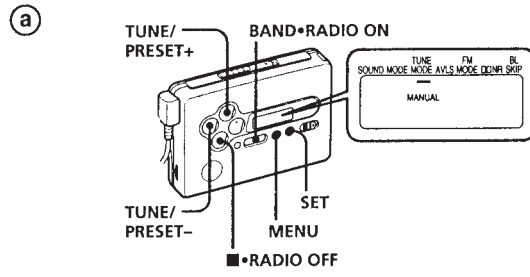

F (FX673)

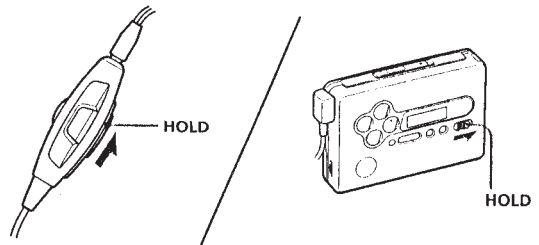

F (FX877)

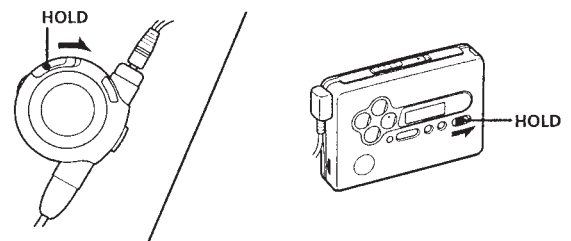

SECTION 3 DISASSEMBLY

This set can be disassembled in the order shown below.

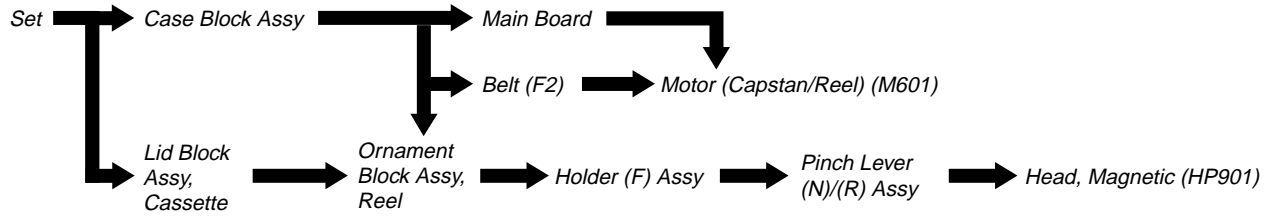

Note: Follow the disassembly procedure in the numerical order given.

CASE BLOCK ASSY

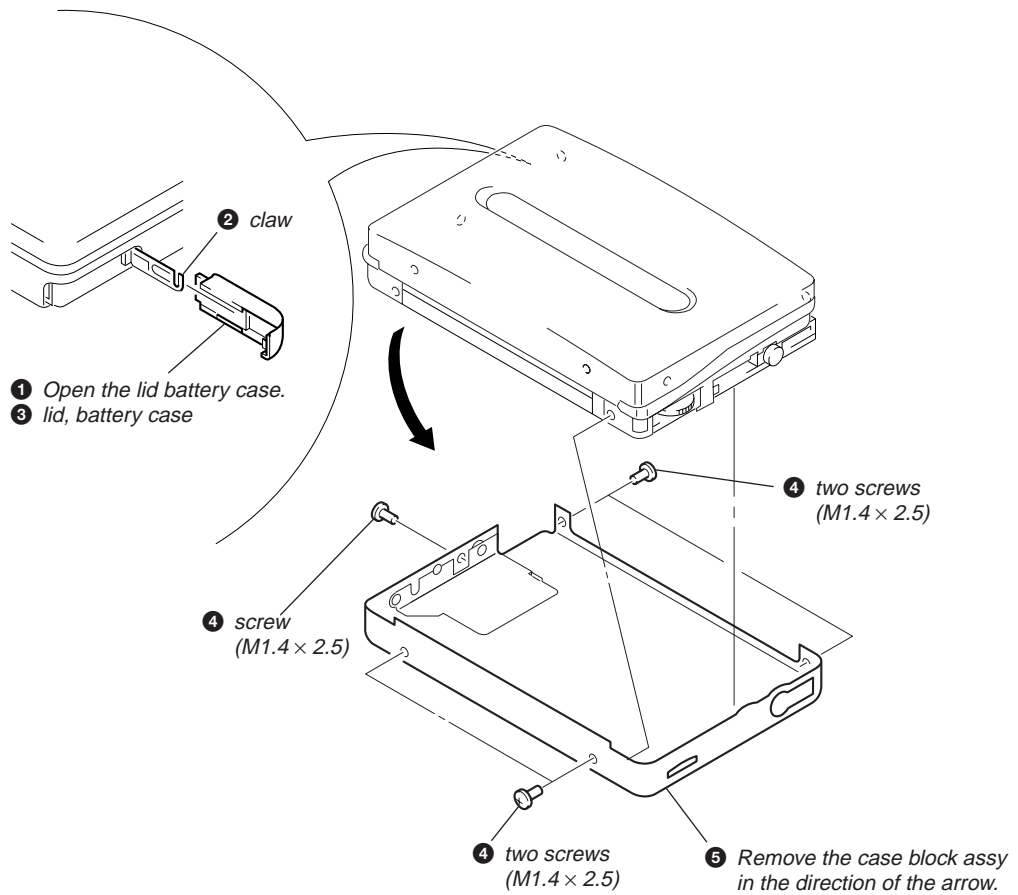

MAIN BOARD

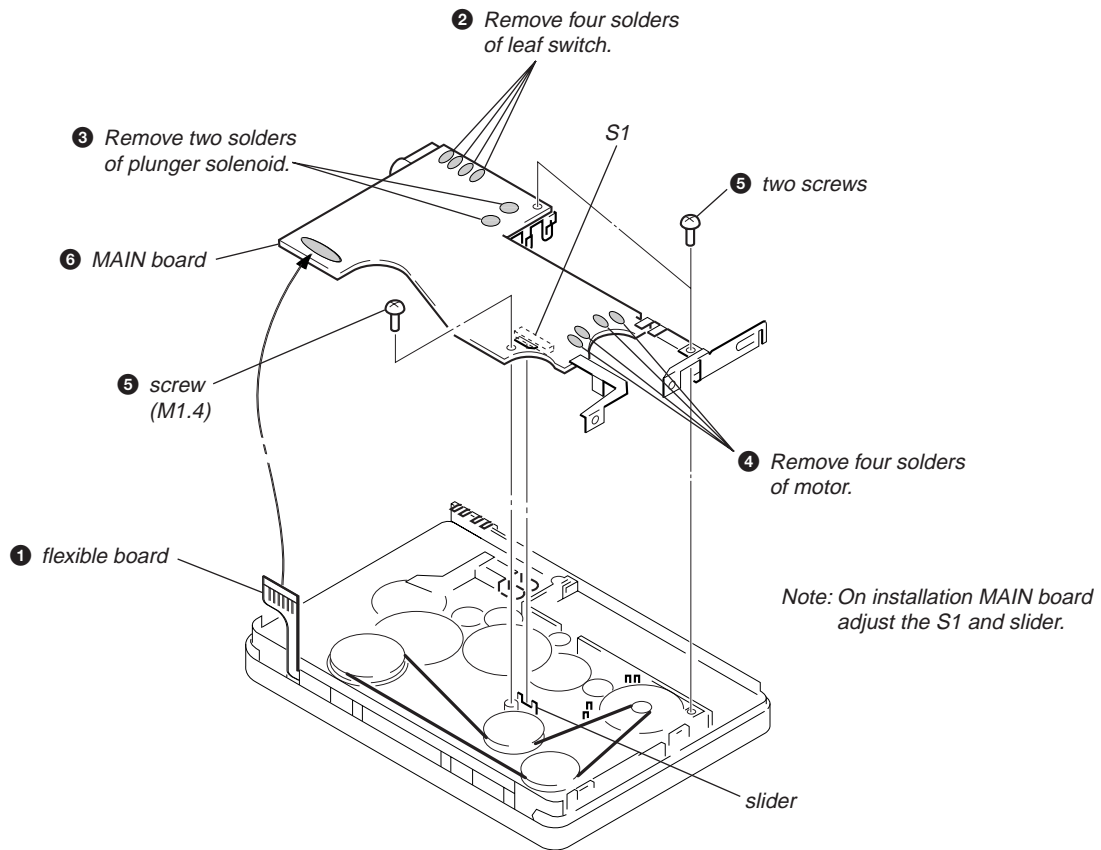

BELT (F2)

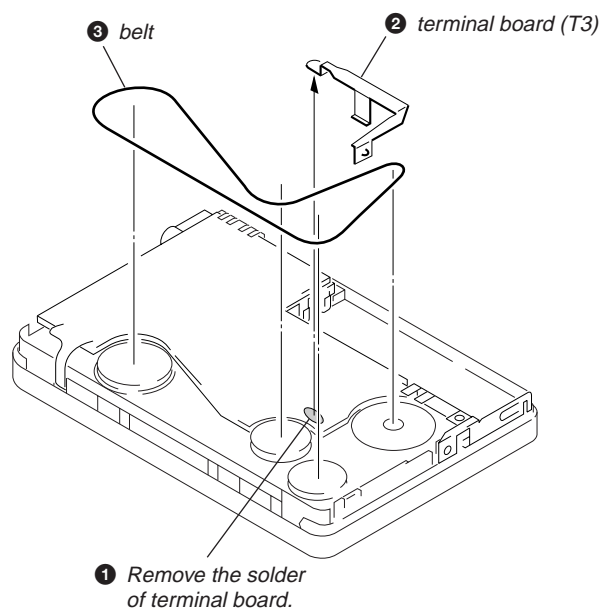

MOTOR (CAPSTAN/REEL) (M601)

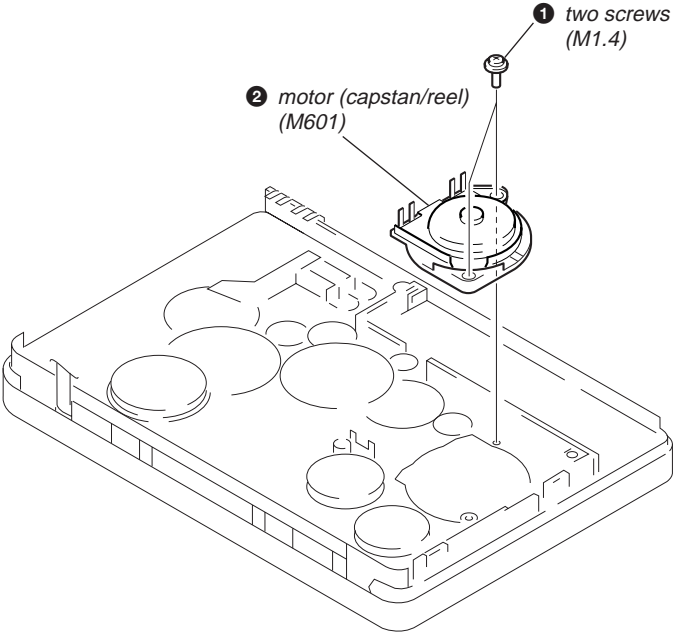

LID BLOCK ASSY, CASSETTE

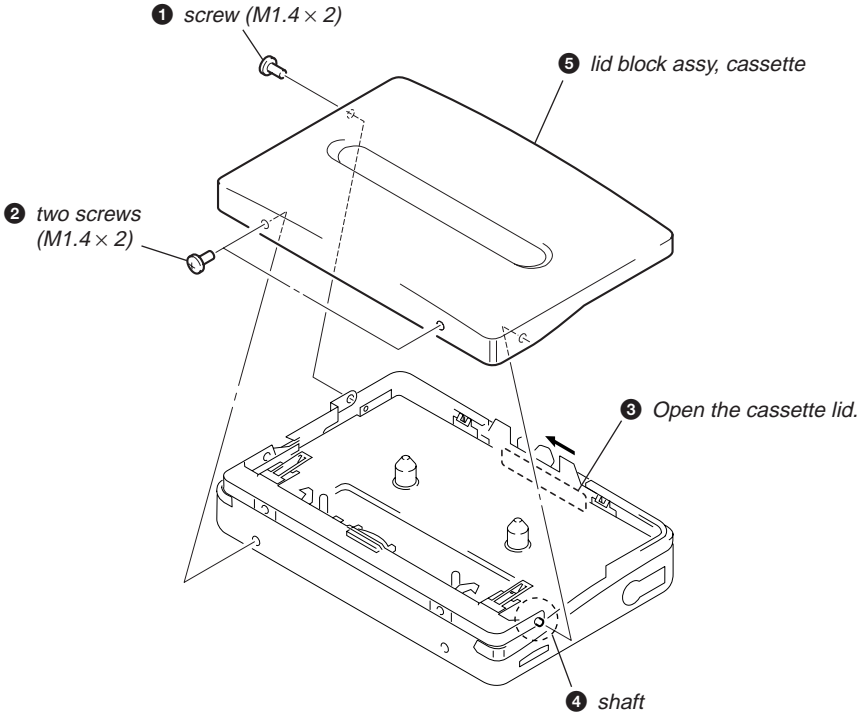

ORNAMENT BLOCK ASSY, REEL

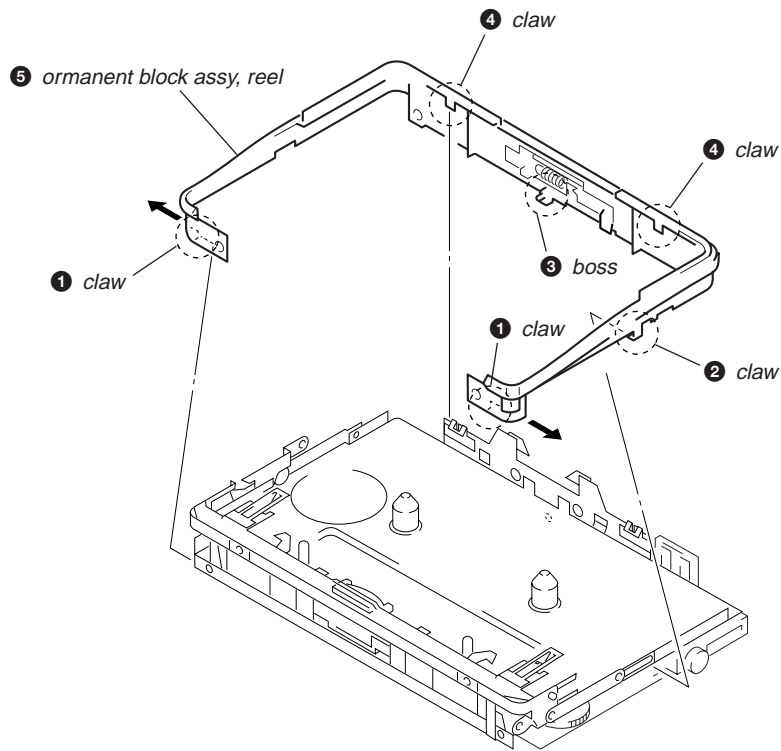

HOLDER (F) ASSY

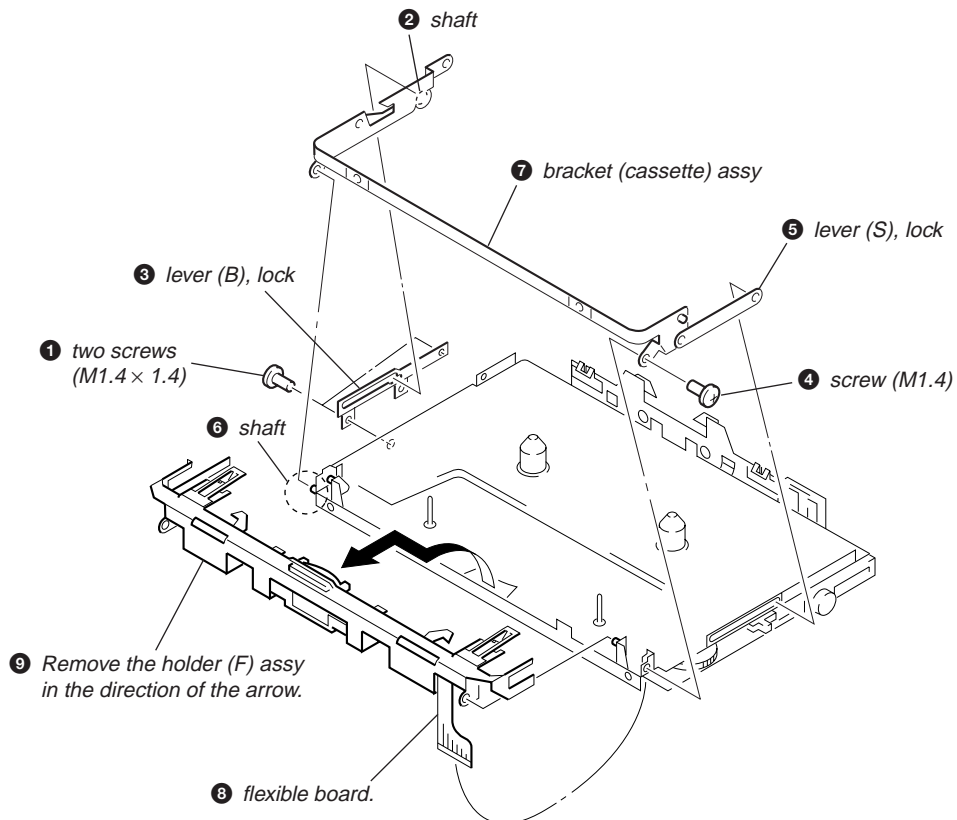

PINCH LEVER (N)/(R) ASSY

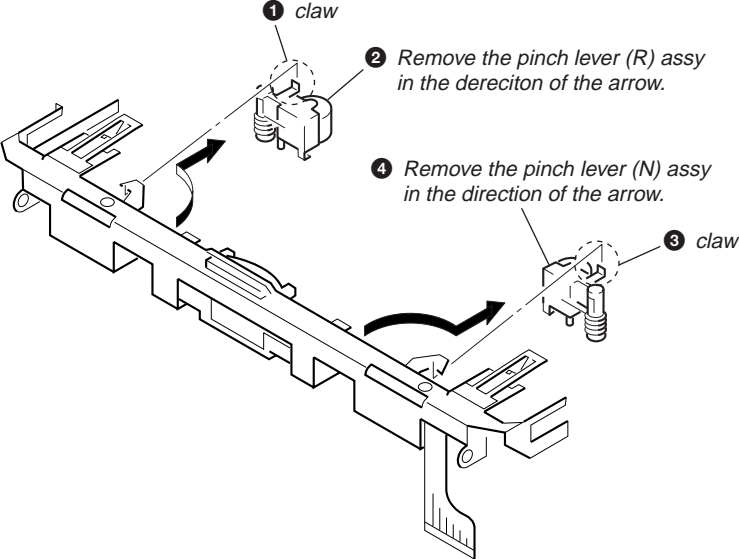

HEAD, MAGNETIC (PLAY BACK) (HP901)

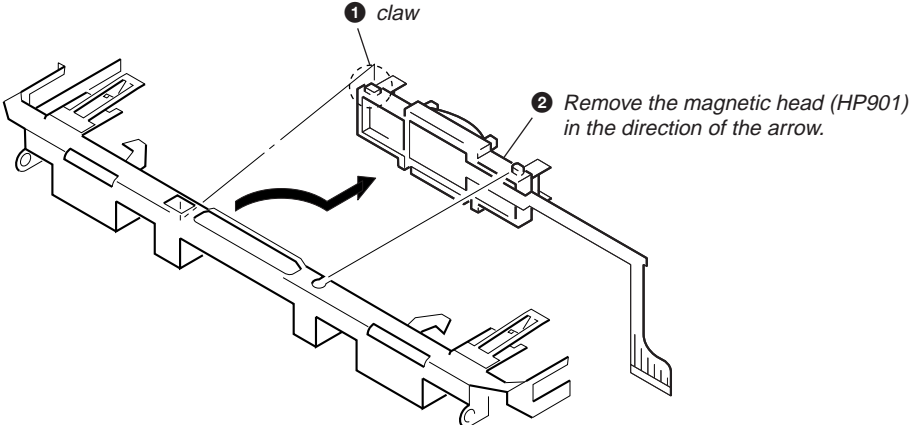

SECTION 4 MECHANICAL ADJUSTMENTS

PRECAUTION

1. Clean the following parts with a denatured-alcohol-moistened swab:

playback head	pinch roller
rubber belts	capstan
2. Demagnetize the playback head with a head demagnetizer.
3. Do not use a magnetized screwdriver for the adjustments.
4. After the adjustments, apply suitable locking compound to the parts adjusted.
5. The adjustments should be performed with the rated power supply voltage (1.3 V) unless otherwise noted.

Torque Measurement

Mode	Torque meter	Meter reading
FWD	CQ-102C	16 – 25 g•cm (0.23 – 0.34 oz•inch)
FWD Back Tension		0.5 – 1.5 g•cm (0.007 – 0.02 oz•inch)
REV	CQ-102RC	16 – 25 g•cm (0.23 – 0.34 oz•inch)
REV Back Tension		0.5 – 1.5 g•cm (0.007 – 0.02 oz•inch)
FF, REV	CQ-201B	more than 50 g•cm (more than 0.7 oz•inch)

SECTION 5 ELECTRICAL ADJUSTMENTS

PRECAUTION

1. Specified voltage : 1.3 V (DC)
2. Setting

BL SKIP	: OFF
SOUND RV/MB/GRV	: OFF
AVLS	: OFF
□□NR	: OFF

TAPE DECK SECTION

0 dB=0.775 V

Test tape

Type	Signal	Used for
WS-48A	3 kHz, 0 dB	Tape Speed Adjustment

Tape Speed Adjustment

Setting:

Function: TAPE

*Test tape
WS-48A
(3 kHz, 0 dB)*

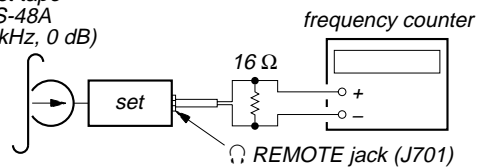

Procedure:

1. Playback WS-48A (tape center) in the FWD state.
2. Adjust RV601 so that the frequency counter reading becomes 3,000 Hz.

Specification Values: 2,970 to 3,030 Hz

3. Playback WS-48A (tape center) in the REV state.
Check that the frequency counter reading is within 2% (approx. 60 Hz) of the reading of step 1.

Adjustment Location: MAIN BOARD (See page 13)

TUNER SECTION

0 dB=1 μ V

[AM]

Setting:

function : RADIO
BAND button : AM

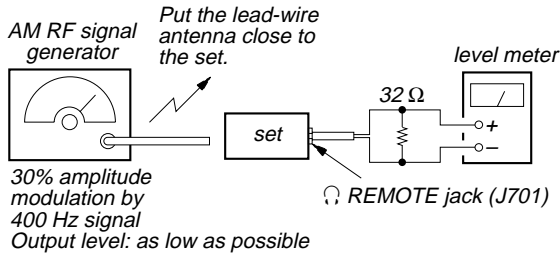

[FM]

Setting:

function : RADIO
BAND button : FM

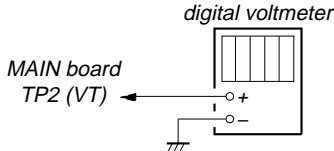
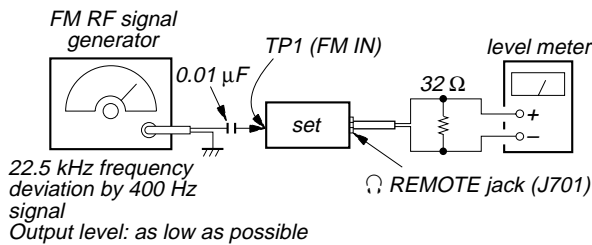

- Repeat the procedures in each adjustment several times, and the tracking adjustments should be finally done by the trimmer capacitors.

AM IF ADJUSTMENT	
Adjust for a maximum reading on level meter	
T2	450 kHz

AM VCO VOLTAGE ADJUSTMENT		
Adjustment Part	Frequency Display	Reading on Digital Voltmeter
T1	531 kHz	1.5 \pm 0.1 V
Confirmation	1602 kHz	8.5 \pm 1 V

AM TRACKING ADJUSTMENT	
Adjust for a maximum reading on level meter	
L5	621 kHz

FM VCO VOLTAGE ADJUSTMENT		
Adjustment Part	Frequency Display	Reading on Digital Voltmeter
L2	87.5 MHz	3.4 \pm 0.1 V
Confirmation	108 MHz	Less than 10 V

FM VCO Adjustment

Setting:

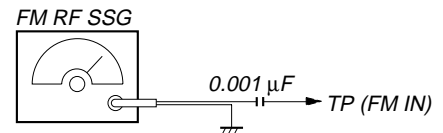

Carrier frequency : 98 MHz
Modulation : no modulation
Output level : 0.1 V (100 dB)

Procedure:

- Connect the frequency counter to pin ⑫ of IC2 as shown the figure below.
- Tune the set to 98 MHz.
- Adjust RV1 for 19 kHz reading on the frequency counter.

Specification: 18.95 kHz to 19.05 kHz

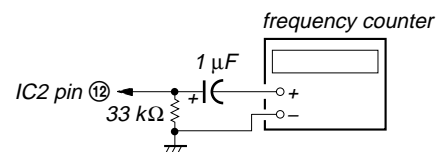

Adjustment Location:

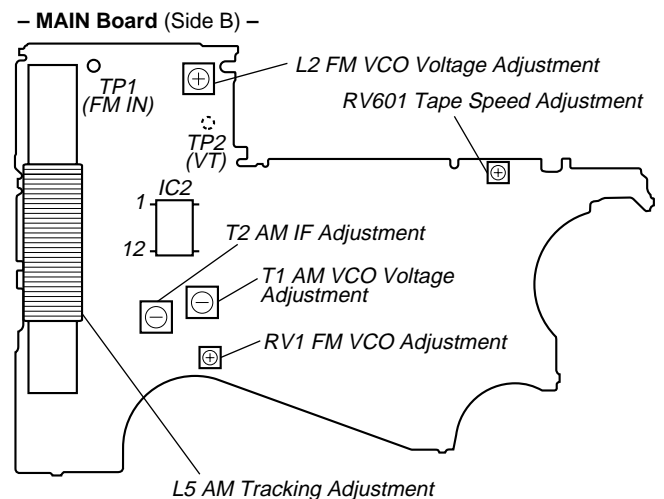

SECTION 6
DIAGRAMS

6-1. BLOCK DIAGRAM - TUNER Section -

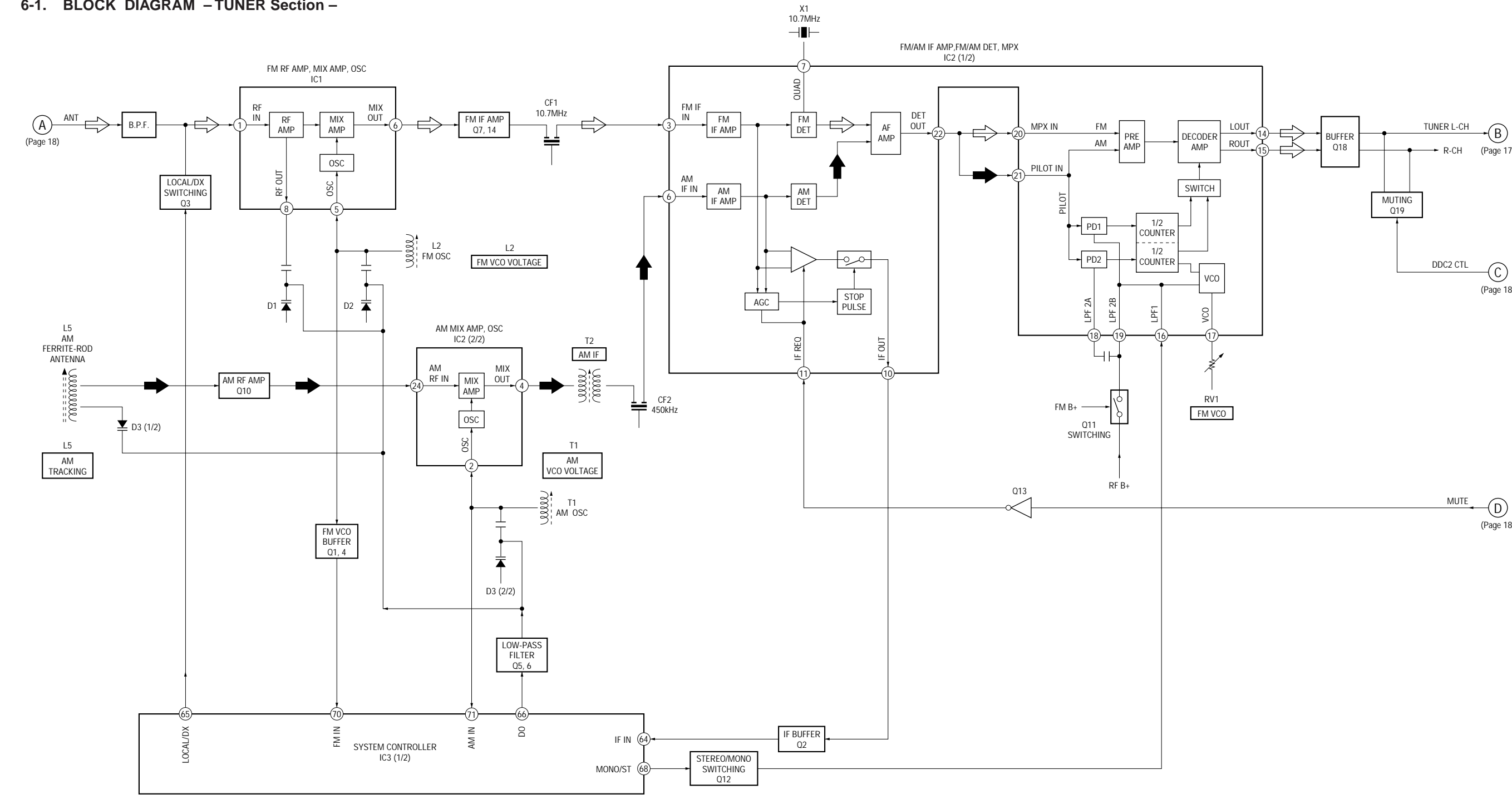

• SIGNAL PATH
 ⇨ : FM
 ⇨ : AM
 R-CH: Same as L-CH

6-2. BLOCK DIAGRAM - MAIN Section -

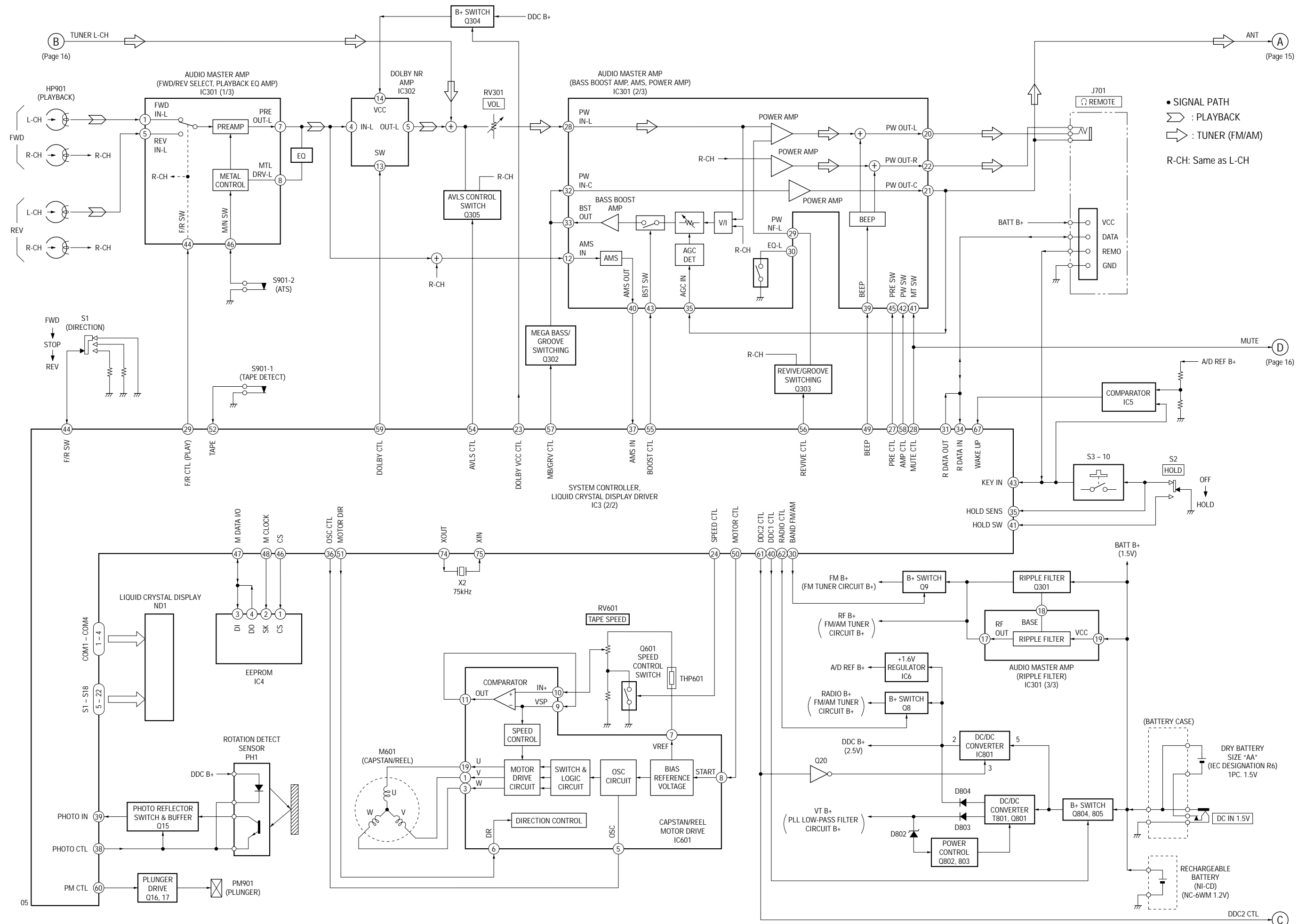

• SIGNAL PATH
 ⇨ : PLAYBACK
 ⇨ : TUNER (FM/AM)
 R-CH: Same as L-CH

6-3. PRINTED WIRING BOARD

	1	2	3	4	5	6	7	8	9	10	11	12	13	14	15	16	17	18	19	20	21	22	23
--	---	---	---	---	---	---	---	---	---	----	----	----	----	----	----	----	----	----	----	----	----	----	----

A

Note on Printed Wiring Board:

- : parts extracted from the component side.
- : parts extracted from the conductor side.
- : Through hole.
- ▨ : Pattern from the side which enables seeing. (The other layers' patterns are not indicated.)

Caution:

Pattern face side: Parts on the pattern face side seen from (Side B) are indicated.

Parts face side: Parts on the parts face side seen from (Side A) are indicated.

This board is four-layer printed board. However, the patterns of layers 2 and 3 have not been included in the diagram.

[MAIN BOARD] (SIDE A)

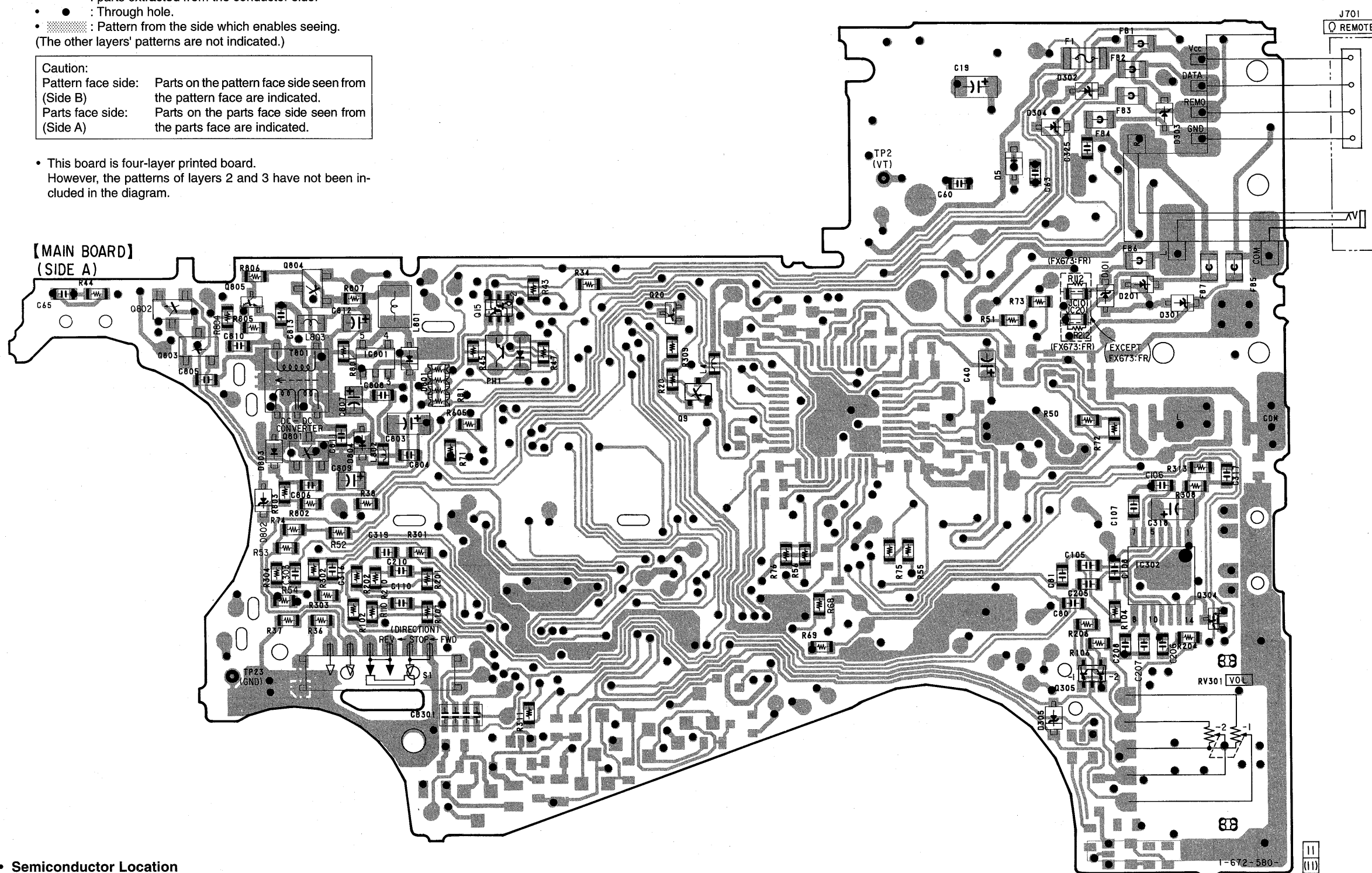

[MAIN BOARD] (SIDE B)

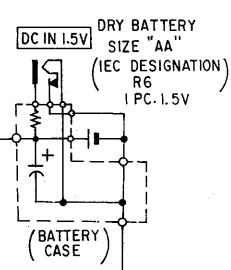
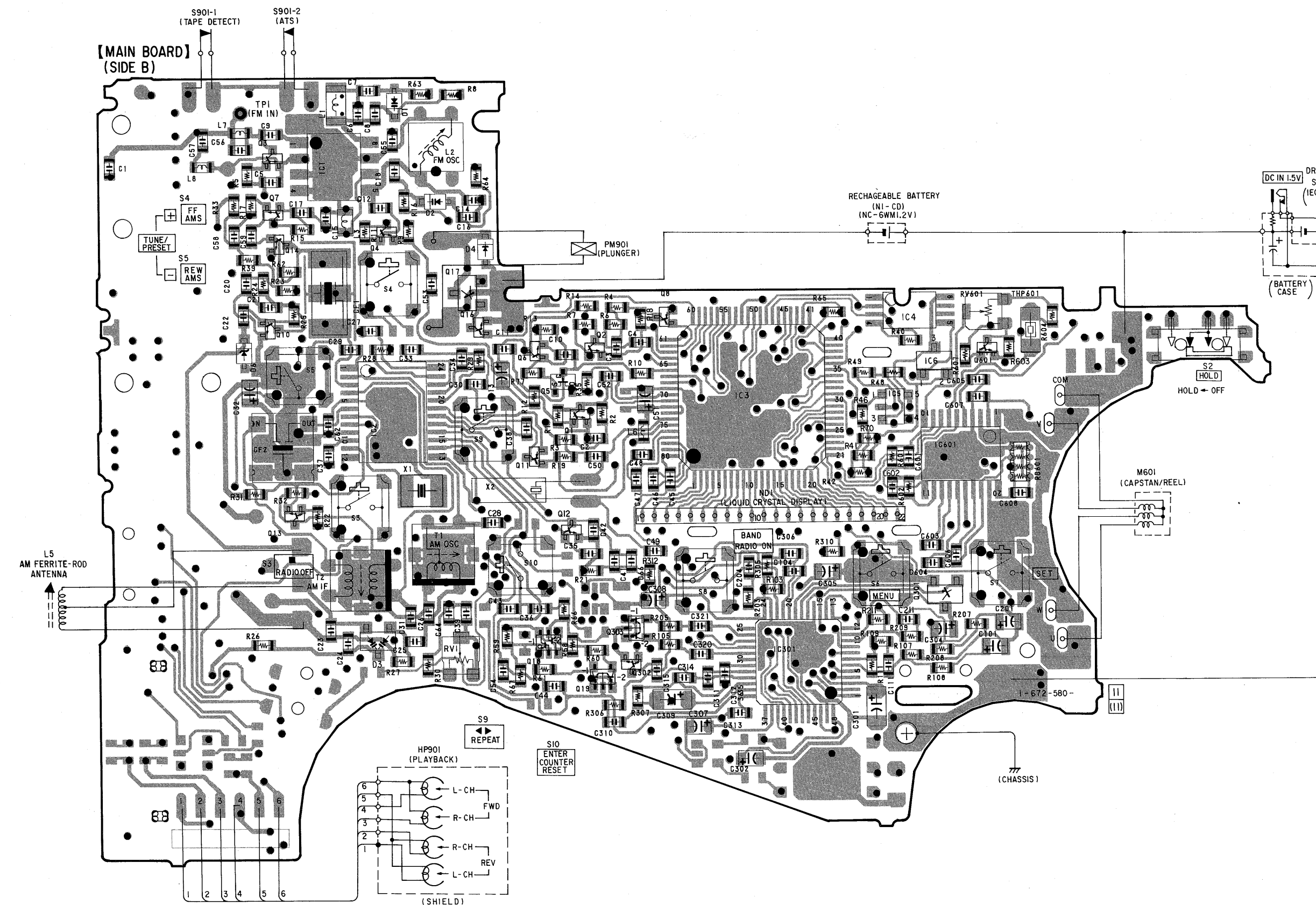

• Semiconductor Location

Ref. No.	Location	Ref. No.	Location	Ref. No.	Location	Ref. No.	Location	Ref. No.	Location	Ref. No.	Location	Ref. No.	Location
D1	B-15	D302	B-9	IC1	B-14	IC801	D-4	Q6	D-16	Q15	D-5	Q304	F-10
D2	B-15	D303	B-10	IC2	D-15			Q7	B-14	Q16	C-15	Q305	F-9
D3	F-15	D304	B-9	IC3	D-18	PH1	D-5	Q8	C-17	Q17	C-15	Q601	D-20
D4	C-15	D305	G-9	IC4	C-19			Q9	D-6	Q18	F-16	Q801	E-3
D5	B-8	D801	D-4	IC5	D-19	Q1	D-16	Q10	C-14	Q19	F-16	Q802	D-2
D6	D-13	D802	E-3	IC6	D-19	Q2	D-16	Q11	D-16	Q20	D-6	Q803	D-2
D101	C-9	D803	E-3	IC301	F-18	Q3	B-14	Q12	E-16	Q301	F-19	Q804	C-3
D201	C-9	D804	E-3	IC302	F-10	Q4	C-15	Q13	E-14	Q302	F-17	Q805	D-3
D301	D-10			IC601	D-19	Q5	D-16	Q14	C-14	Q303	F-17		

Note on Schematic Diagram:

- All capacitors are in μF unless otherwise noted. pF : μF
- 50 WV or less are not indicated except for electrolytics and tantalums.
- All resistors are in Ω and $1/4\text{-}W$ or less unless otherwise specified.
- % : indicates tolerance.
- : panel designation.
- B+ : B+ Line.
- ⊕ : adjustment for repair.
- Total current is measured with no cassette installed.
- Power voltage is dc 1.5 V and fed with regulated dc power supply from battery terminal.
- Voltages and waveforms are dc with respect to ground under no-signal (detuned) conditions.
- no mark : PLAYBACK
- () : FM
- () : AM
- Voltages are taken with a VOM (input impedance 10 M Ω). Voltage variations may be noted due to normal production tolerances.
- Waveforms are taken with an oscilloscope. Voltage variations may be noted due to normal production tolerances.
- Circled numbers refer to waveforms.
- Signal path
- ◁ : FM
- ▷ : AM
- ◁ ▷ : PLAYBACK
- Abbreviation
- FR : French model

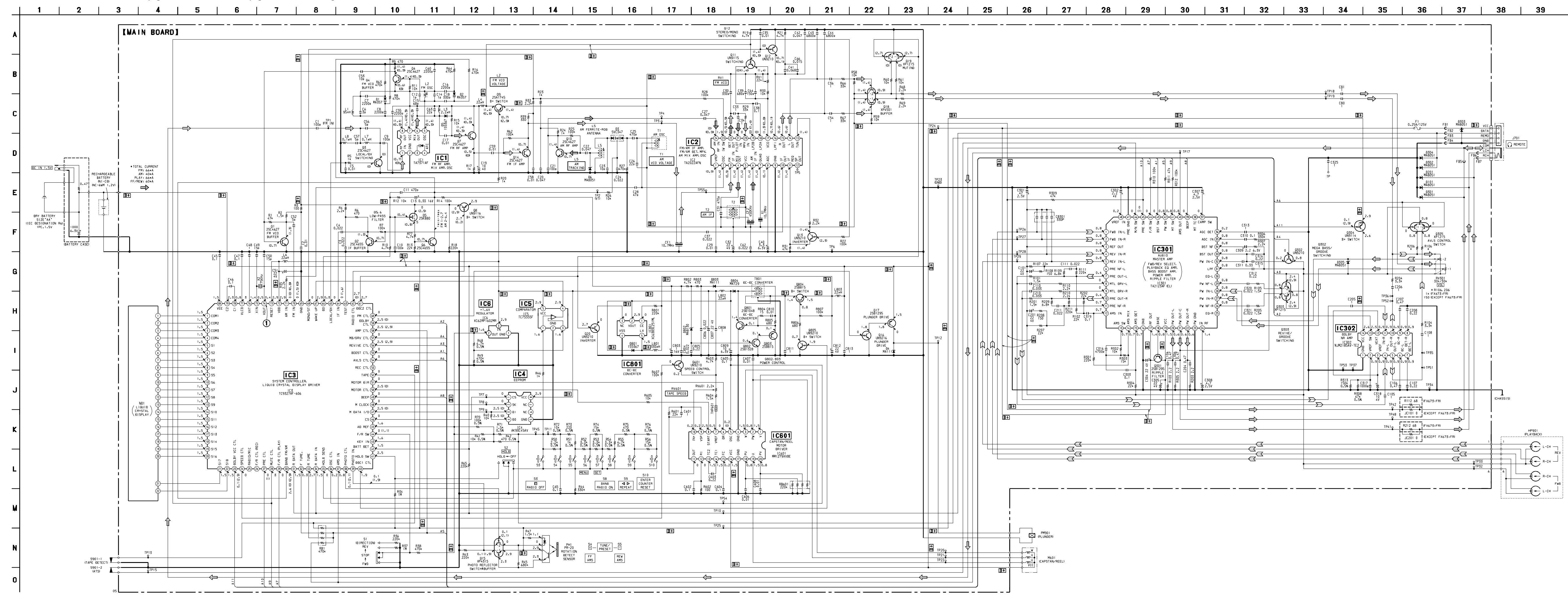

• Waveform
– MAIN BOARD –

① IC3 (X OUT)
500 mV/DIV, 5 μs/DIV

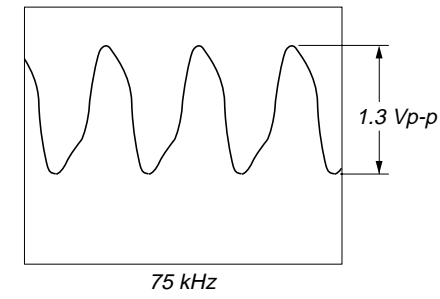

• IC Block Diagrams

IC1 TA7371AF-EL

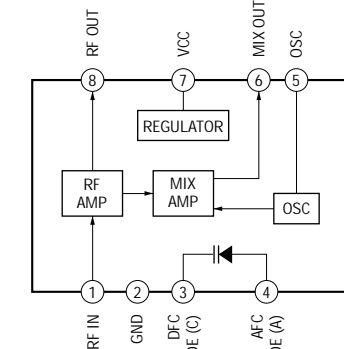

IC2 TA2022AFN-EL

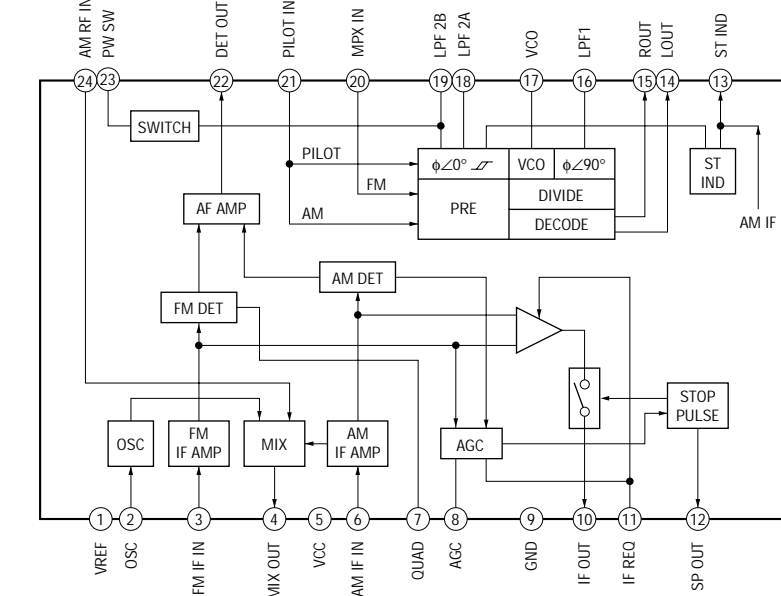

IC302 NJM2185AV-TE2

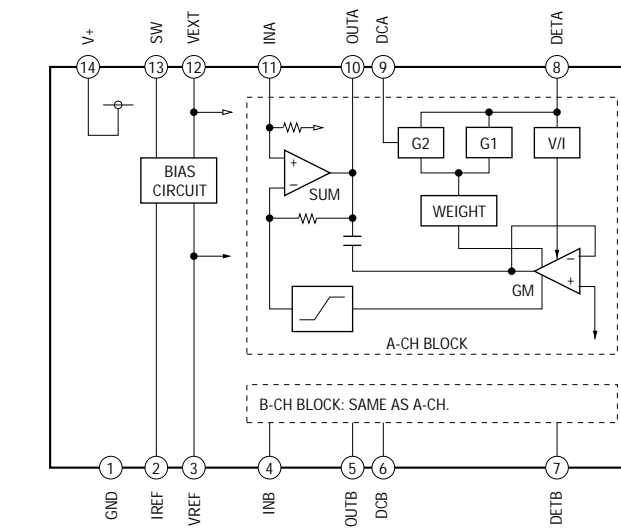

IC301 TA2123AF (EL)

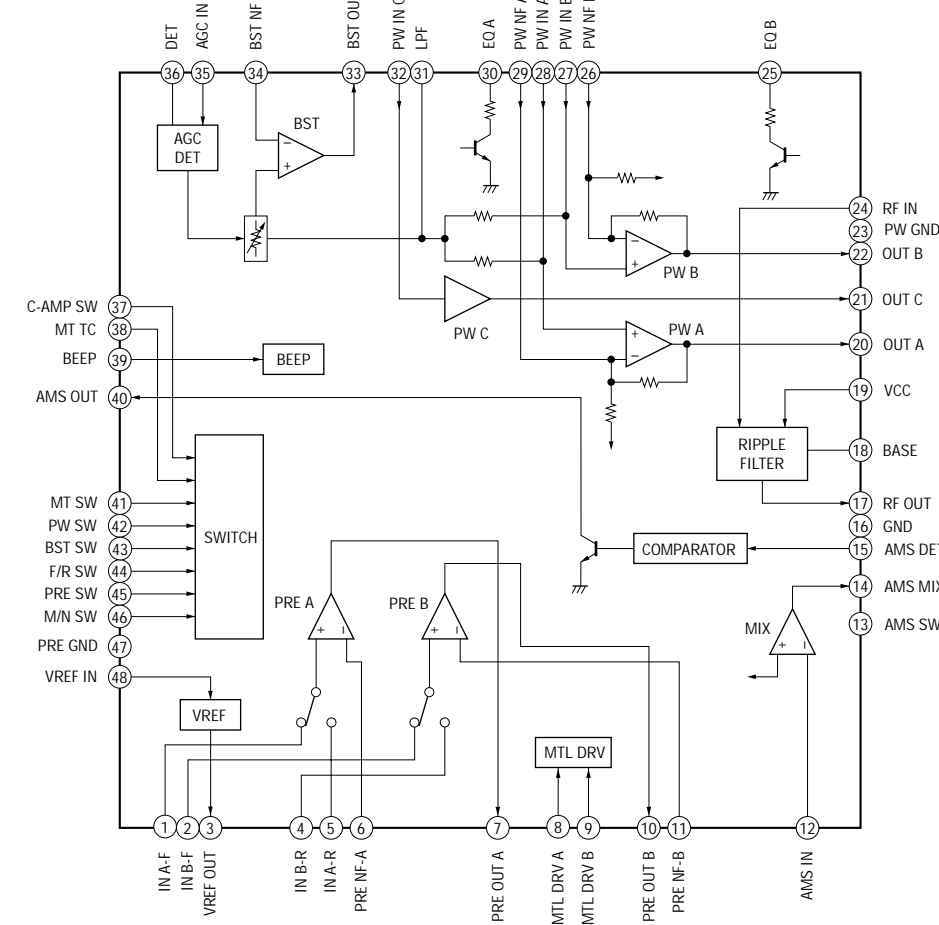

IC601 MM1279XVBE

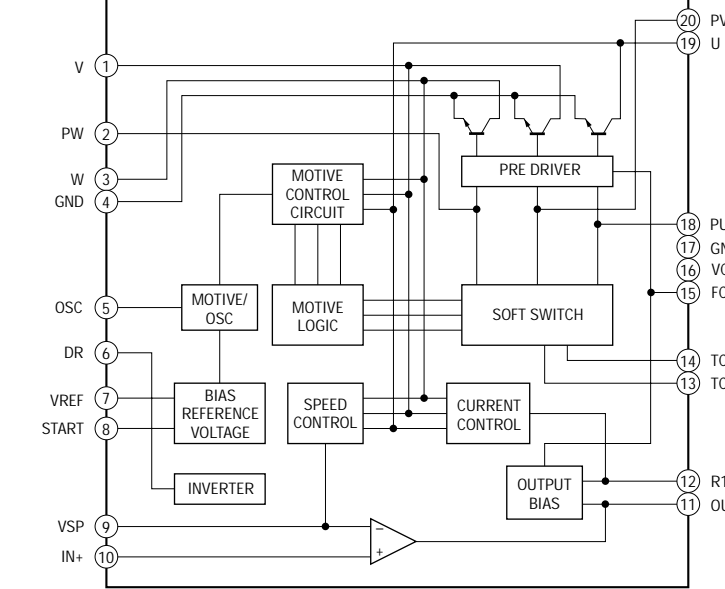

6-5. IC PIN FUNCTION DESCRIPTION

• MAIN BOARD IC3 TC9327AF-606 (SYSTEM CONTROLLER, LIQUID CRYSTAL DISPLAY DRIVER)

Pin No.	Pin Name	I/O	Description
1 to 4	COM1 to COM4	O	Common drive signal output to the liquid crystal display (LCD1)
5 to 22	S1 to S18	O	Segment drive signal output to the liquid crystal display (LCD1)
23	DOLBY VCC CTL	O	Power on/off control signal output of the dolby NR amp (IC302) "L": power on, "H": power off
24	SPEED CTL	O	Motor speed control signal output to the capstan/reel motor driver IC (IC601) "L": normal speed, "H": 1/2 speed
25	RADIO/MIC	O	Not used (open)
26	F/R CTL (REC)	O	Not used (open)
27	PRE CTL	O	Preamp on/off control signal output to the TA2123AF (IC301) "L": tape play, "H": radio on
28	MUTE CTL	O	Power on mute control signal output to the TA2123AF (IC301) "L": mute on
29	F/R CTL (PLAY)	O	Forward/reverse selection signal output to the TA2123AF (IC301) "L": reverse direction, "H": forward direction
30	BAND FM/AM	O	Power on/off control signal output of the FM circuit "L": power on (FM on), "H": power off (AM or tape on)
31	R DATA OUT	O	Remote control data output to the remote commander
32	F TUNE	I	"H" is input when amplifier on mode
33	R TUNE	I	"H" is input when amplifier on mode
34	R DATA IN	I	Communication request input from the remote commander
35	HOLD SENS	I	Hold status input of the HOLD switch (S2) "L": hold off, "H": hold on "H" is input when key pressing at hold mode
36	OSC CTL	O	Motor restart control signal output to the capstan/reel motor driver IC (IC601) "L": BL skip status, "H": FF/REW motor rotation status
37	AMS IN	I	Whether a music is present or not from TA2123AF (IC301) is detected at auto music sensor "L": music is present, "H": music is not present
38	PHOTO CTL	O	Control signal output to the capstan/reel motor rotation detect circuit "L": rotation detect circuit on
39	PHOTO IN	I	Rotation detect signal input of the capstan/reel motor (M601)
40	DDC1 CTL	O	Power on/off control signal output of the DC/DC converter circuit "L": power off, "H": power on
41	HOLD SW	I	Hold detect input from the HOLD switch (S2) "L": hold on
42	BATT DET	I	Battery voltage detection signal input (A/D input)
43	KEY IN	I	Key input terminal (A/D input)
44	F/R SW	I	Tape direction switch (S1) input terminal (A/D input) "L": forward position
45	A/D REF	I	Reference voltage (+1.6V) input for the A/D converter
46	CS	O	Chip select signal output to the EEPROM (IC4)
47	M DATA I/O	I/O	Two-way data bus with the EEPROM (IC4)
48	M CLOCK	O	Serial clock signal output to the EEPROM (IC4)
49	BEEP	O	Beep sound signal output to the TA2123AF (IC301)
50	MOTOR CTL	O	Motor start control signal output to the capstan/reel motor driver IC (IC601) "L": motor off, "H": motor on
51	MOTOR DIR	O	Motor direction control signal output to the capstan/reel motor driver IC (IC601) "L": clockwise, "H": counterclockwise
52	TAPE	I	Cassette tape detect switch (S901-1) input terminal "L": cassette detected, "H": no cassette
53	REC CTL	O	Not used (open)
54	AVLS CTL	O	AVLS (Automatic Volume Limiter System) on/off control signal output terminal "L": AVLS on "H": AVLS off

Pin No.	Pin Name	I/O	Description
55	BOOST CTL	O	Bass boost control signal output to the TA2123AF (IC301) "L": off, "H": on
56	REVIVE CTL	O	Emphasizing sound control signal output to the TA2123AF (IC301) "L": RV (revive), "H": normal/MB (mega bass)/GRV (groove)
57	MB/GRV CTL	O	Emphasizing sound control signal output to the TA2123AF (IC301) "L": normal/RV (revive)/GRV (groove), "H": MB (mega bass)
58	AMP CTL	O	Power on/off control signal output to the TA2123AF (IC301) "L": power off, "H": power on
59	DOLBY CTL	O	Dolby on/off control signal output to the dolby NR amp (IC302) "L": dolby NR on, "H": dolby NR off
60	PM CTL	O	Plunger drive signal output terminal "L": plunger on
61	DDC2 CTL	O	Power on/off control signal output of the DC/DC converter circuit "L": power off, "H": power on
62	RADIO CTL	O	Power on/off control signal output of the FM and AM circuit "L": power on (FM or AM on), "H": power off (tape on)
63	TEST	I	Test input terminal Normally: fixed at "L"
64	IF IN	I	Intermediate frequency detect signal input from the TA2022AFN (IC2)
65	LOCAL/DX	O	Local/DX select signal output terminal "L": DX, "H": local
66	DO	O	PLL error signal output terminal
67	WAKE UP	I	Input of acknowledge signal for the key entry Acknowledge signal is input to accept function in the power off status On at input of "H"
68	MONO/ST	O	FM stereo/mono select signal output to the TA2022AFN (IC2) "L": stereo, "H": mono
69	GND	—	Ground terminal
70	FM IN	I	FM VCO input terminal
71	AM IN	I	AM (MW) VCO input terminal
72	VDD	—	Power supply terminal (+2.5V)
73	RESET	I	System reset signal input terminal "L": reset
74	XOUT	O	System clock output terminal (75 kHz)
75	XIN	I	System clock input terminal (75 kHz)
76	VXT	—	Terminal to which external capacitor is connected to stabilize crystal oscillator power supply
77	VLCD	—	Terminal for doubler circuit capacitor connection to develop liquid crystal display drive voltage
78	C1	—	
79	C2	—	
80	VEE	—	

SECTION 7 EXPLODED VIEWS

NOTE:

- -XX and -X mean standardized parts, so they may have some difference from the original one.
- Color Indication of Appearance Parts
Example:
KNOB, BALANCE (WHITE) . . . (RED)
 ↑ ↑
 Parts Color Cabinet's Color

- Items marked "***" are not stocked since they are seldom required for routine service. Some delay should be anticipated when ordering these items.
- The mechanical parts with no reference number in the exploded views are not supplied.
- Accessories and packing materials are given in the last of the electrical parts list.

- Abbreviation
AUS : Australian model
CH : Chinese model
CND : Canadian model
EA : Saudi Arabia model
EE : East European model
FR : French model
HK : Hong Kong model
JE : Tourist model
KR : Korean model

(1) CASE SECTION

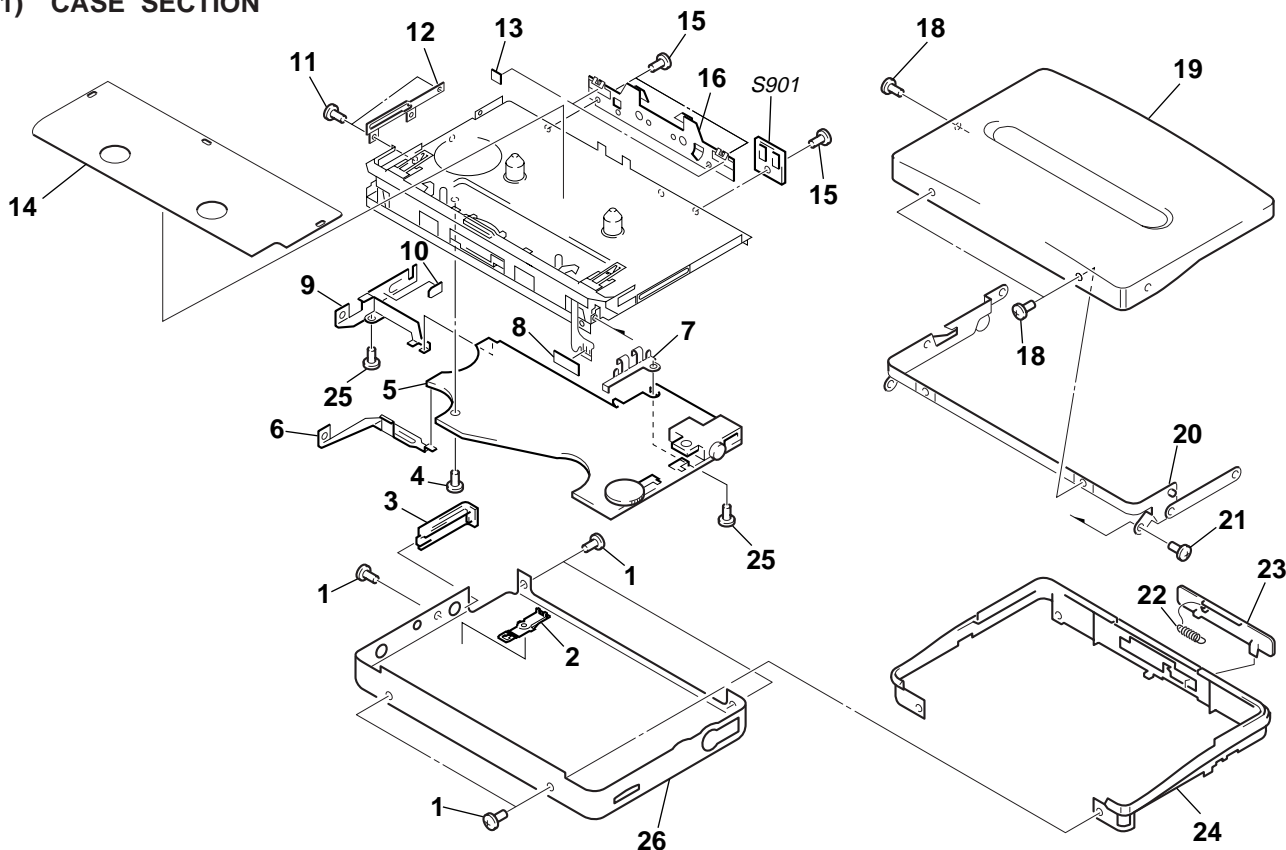

Ref. No.	Part No.	Description	Remark	Ref. No.	Part No.	Description	Remark
1	3-704-197-21	SCREW (M1.4X2.5), LOCKING (FX877: JE, KR)		15	3-366-892-01	SCREW (M1.4)	
1	3-704-197-23	SCREW (M1.4X2.5), LOCKING		16	X-3376-277-2	BRACKET ASSY	
2	3-034-075-01	LEVER (HOLD)		18	3-704-197-11	SCREW (M1.4X2.0), LOCKING (FX877: KR, JE)	
3	3-034-068-01	LID, BATTERY (FX877: JE) (SILVER)		18	3-704-197-13	SCREW (M1.4X2.0), LOCKING	
3	3-034-068-11	LID, BATTERY (FX877: JE) (BLUE)		19	X-3377-332-1	LID ASSY (F-S), CASSETTE (FX673/FX877: CH)	
3	3-034-068-21	LID, BATTERY (FX673/FX877: CH, KR)		19	X-3377-528-1	LID ASSY (F-SJ), CASSETTE (FX877: JE, KR) (SILVER)	
3	3-034-068-31	LID, BATTERY (FX877: KR) (BLUE)		19	X-3377-529-1	LID ASSY (F-LJ), CASSETTE (FX877: KR, JE) (BLUE)	
4	3-345-648-71	SCREW (M1.4), TOOTHED LOCK		20	X-3376-279-1	BRACKET (CASSETTE) ASSY	
5	A-3021-222-A	MAIN, BOARD COMPLETE (EXCEPT FX673: FR/FX877: JE)		21	3-365-630-41	SCREW (M1.4)	
5	A-3021-223-A	MAIN, BOARD COMPLETE (FX673: FR)		22	3-029-220-01	SPRING, TENSION	
5	A-3021-237-A	MAIN, BOARD COMPLETE (FX877: JE)		23	3-029-219-01	KNOB (OPEN)	
6	3-029-213-02	TERMINAL BOARD (T3)		24	3-034-072-11	ORNAMENT, REEL	
7	3-029-210-01	TERMINAL BOARD (MINUS)		25	3-375-114-41	SCREW	
8	3-309-595-11	SHEET, INSULATING, PACK (FX877: CH, JE)		26	X-3377-347-1	CASE (FX-AS3) ASSY (FX673: CND, E, EA, HK, AUS)	
9	X-3377-281-1	TERMINAL BOARD ASSY, BATTERY		26	X-3377-348-1	CASE (FX-AS7M) ASSY (FX877: KR)	
10	3-031-460-01	SHEET (BT)		26	X-3377-349-1	CASE (FX-AS7M) ASSY (FX877: CH)	
11	3-366-892-11	SCREW (M1.4X1.4)		26	X-3377-357-1	CASE (FX-AS30) ASSY (FX673: AEP, UK, FR, EE)	
12	3-029-217-01	LEVER (B), LOCK		26	X-3377-366-1	CASE (FX-AL7J) ASSY (FX877: KR, JE) (BLUE)	
13	3-328-483-11	SHEET		26	X-3377-367-1	CASE (FX-AS7J) ASSY (FX877: KR, JE) (SILVER)	
14	3-029-205-01	COVER, MD (FX877: JE)		S901	1-762-553-11	SWITCH, LEAF (TAPE DETECT, ATS)	
14	3-029-205-11	COVER, MD (FX673: AEP, UK, FR, EE)					
14	3-029-205-21	COVER, MD (FX673: CND, E, EA, HK, AUS/FX877: CH)					

**(2) MECHANISM DECK SECTION
(MT-WMEX672-162)**

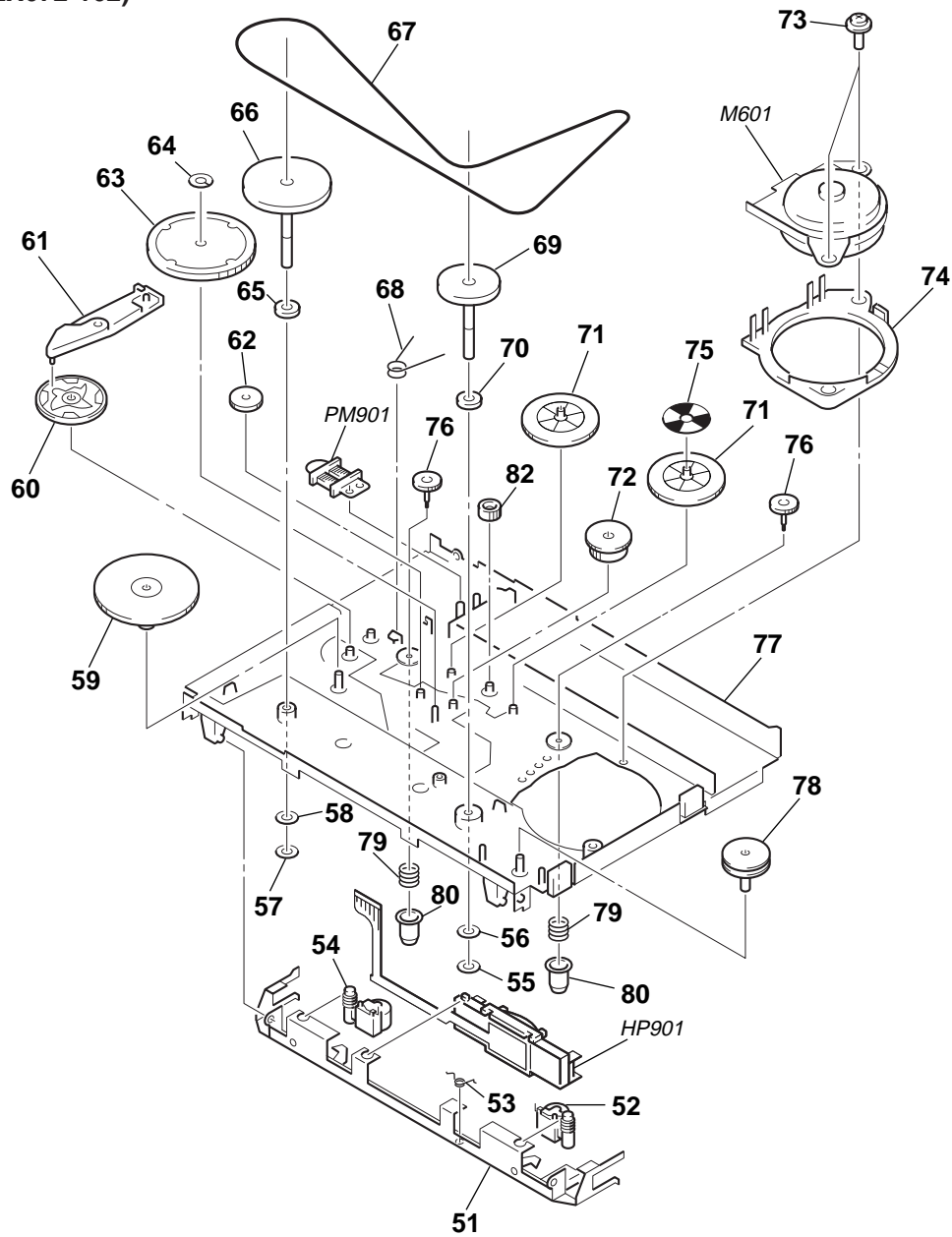

Ref. No.	Part No.	Description	Remark	Ref. No.	Part No.	Description	Remark
51	X-3376-293-1	HOLDER (F) ASSY (FX877)		68	3-029-287-01	SPRING (TG), TORSION	
51	X-3377-039-1	HOLDER (F) ASSY (M) (FX673)		69	3-029-268-01	FLYWHEEL (R), INSERT (FX877)	
52	X-3377-363-1	PINCH LEVER (R) ASSY		69	3-029-268-11	FLYWHEEL (R), INSERT (FX673)	
53	3-029-271-01	SPRING (HD)		70	3-007-428-01	WASHER (R)	
54	X-3377-362-1	PINCH LEVER (N) ASSY		71	3-029-283-01	GEAR, IDLER (A)	
55	3-029-276-01	WASHER (STOPPER R)		72	3-029-286-01	GEAR (NR)	
56	3-029-289-01	WASHER		73	3-029-765-01	SCREW (M1.4), TOOTHED LOCK	
57	3-029-275-01	WASHER (STOPPER N)		74	3-029-274-02	RETAINER (F2), MOTOR	
58	3-029-278-01	WASHER		75	3-007-433-01	SHEET (N), REFLECTION	
59	3-029-282-01	GEAR (Y)		76	3-010-273-02	GEAR (REEL)	
60	3-029-285-01	GEAR, CAM		77	X-3376-291-4	CHASSIS ASSY (F) (FX877)	
61	3-029-284-01	LEVER, TRIGGER		77	X-3377-037-2	CHASSIS ASSY (F) (M) (FX673)	
62	3-029-281-01	GEAR, IDLER (B)		78	3-029-288-01	PULLEY, REVERSE	
63	X-3376-813-1	CLUTCH ASSY (F)		79	3-010-954-01	SPRING (BT), COMPRESSION	
64	3-932-724-21	WASHER		80	3-010-274-02	TABLE, REEL	
65	3-386-694-01	WASHER		82	3-029-273-01	GEAR (FR)	
66	3-029-306-01	FLYWHEEL (N), INSERT (FX877)		HP901	1-500-576-11	HEAD, MAGNETIC (PLAYBACK)	
66	3-029-306-11	FLYWHEEL (N), INSERT (FX673)		M601	1-763-166-12	MOTOR (CAPSTAN/REEL)	
67	3-029-280-01	BELT (F2)		PM901	1-454-674-32	SOLENOID, PLUNGER	

SECTION 8 ELECTRICAL PARTS LIST

NOTE:

- Due to standardization, replacements in the parts list may be different from the parts specified in the diagrams or the components used on the set.
- -XX and -X mean standardized parts, so they may have some difference from the original one.
- **RESISTORS**
All resistors are in ohms.
METAL: Metal-film resistor.
METAL OXIDE: Metal oxide-film resistor.
F: nonflammable
- **Abbreviation**
AUS : Australian model EA : Saudi Arabia model HK : Hong Kong model
CH : Chinese model EE : East European model JE : Tourist model
CND : Canadian model FR : French model KR : Korean model

- Items marked “**” are not stocked since they are seldom required for routine service. Some delay should be anticipated when ordering these items.
- **SEMICONDUCTORS**
In each case, u: μ , for example:
uA. . : μ A. . uPA. . : μ PA. .
uPB. . : μ PB. . uPC. . : μ PC. .
uPD. . : μ PD. .
- **CAPACITORS**
uF: μ F
- **COILS**
uH: μ H

The components identified by mark Δ or dotted line with mark Δ are critical for safety. Replace only with part number specified.

Les composants identifiés par une marque Δ sont critiques pour la sécurité. Ne les remplacer que par une pièce portant le numéro spécifié.

When indicating parts by reference number, please include the board.

Ref. No.	Part No.	Description	Remark	Ref. No.	Part No.	Description	Remark
	A-3021-222-A	MAIN BOARD, COMPLETE (EXCEPT FX673: FR/FX877: JE)		C36	1-115-156-11	CERAMIC CHIP 1uF	10V
	A-3021-223-A	MAIN BOARD, COMPLETE (FX673: FR)		C37	1-164-227-11	CERAMIC CHIP 0.022uF	10% 25V
	A-3021-237-A	MAIN BOARD, COMPLETE (FX877: JE) *****		C38	1-107-826-91	CERAMIC CHIP 0.1uF	10% 16V
	1-694-502-11	CONDUCTIVE BOARD, CONNECTION		C39	1-115-412-11	CERAMIC CHIP 680PF	5% 25V
	3-034-073-01	HOLDER (LCD)		C40	1-127-578-91	TANTAL. CHIP 3.3uF	20% 6.3V
		< CAPACITOR >		C41	1-110-563-11	CERAMIC CHIP 0.068uF	10% 16V
C1	1-162-927-11	CERAMIC CHIP 100PF	5% 50V	C42	1-165-176-11	CERAMIC CHIP 0.047uF	10% 16V
C2	1-162-970-11	CERAMIC CHIP 0.01uF	10% 25V	C43	1-162-969-11	CERAMIC CHIP 0.0068uF	10% 25V
C3	1-164-227-11	CERAMIC CHIP 0.022uF	10% 25V	C44	1-162-969-11	CERAMIC CHIP 0.0068uF	10% 25V
C4	1-164-227-11	CERAMIC CHIP 0.022uF	10% 25V	C45	1-164-360-11	CERAMIC CHIP 0.1uF	16V
C5	1-162-970-11	CERAMIC CHIP 0.01uF	10% 25V	C46	1-164-360-11	CERAMIC CHIP 0.1uF	16V
C6	1-162-908-11	CERAMIC CHIP 3PF	0.25PF 50V	C47	1-164-360-11	CERAMIC CHIP 0.1uF	16V
C7	1-164-676-11	CERAMIC CHIP 2200PF	5% 16V	C48	1-115-156-11	CERAMIC CHIP 1uF	10V
C8	1-164-676-11	CERAMIC CHIP 2200PF	5% 16V	C49	1-162-917-11	CERAMIC CHIP 15PF	5% 50V
C9	1-162-927-11	CERAMIC CHIP 100PF	5% 50V	C50	1-162-917-11	CERAMIC CHIP 15PF	5% 50V
C10	1-162-927-11	CERAMIC CHIP 100PF	5% 50V	C51	1-125-984-21	TANTAL. CHIP 22uF	20% 4V
C11	1-162-962-11	CERAMIC CHIP 470PF	10% 50V	C52	1-162-910-11	CERAMIC CHIP 5PF	0.25PF 50V
C12	1-162-905-11	CERAMIC CHIP 1PF	0.25PF 50V	C53	1-162-915-11	CERAMIC CHIP 10PF	0.5PF 50V
C13	1-107-817-11	TANTAL. CHIP 0.33uF	10% 16V	C54	1-115-156-11	CERAMIC CHIP 1uF	10V
C14	1-162-905-11	CERAMIC CHIP 1PF	0.25PF 50V	C55	1-164-676-11	CERAMIC CHIP 2200PF	5% 16V
C15	1-162-925-11	CERAMIC CHIP 68PF	5% 50V	C56	1-162-910-11	CERAMIC CHIP 5PF	0.25PF 50V
C16	1-164-676-11	CERAMIC CHIP 2200PF	5% 16V	C57	1-162-910-11	CERAMIC CHIP 5PF	0.25PF 50V
C17	1-162-970-11	CERAMIC CHIP 0.01uF	10% 25V	C58	1-162-970-11	CERAMIC CHIP 0.01uF	10% 25V
C18	1-162-959-11	CERAMIC CHIP 330PF	5% 50V	C59	1-162-970-11	CERAMIC CHIP 0.01uF	10% 25V
C19	1-135-201-11	TANTAL. CHIP 10uF	20% 4V	C60	1-164-676-11	CERAMIC CHIP 2200PF	5% 16V
C20	1-165-176-11	CERAMIC CHIP 0.047uF	10% 16V	C62	1-164-227-11	CERAMIC CHIP 0.022uF	10% 25V
C21	1-162-927-11	CERAMIC CHIP 100PF	5% 50V	C63	1-162-919-11	CERAMIC CHIP 22PF	5% 50V
C22	1-165-176-11	CERAMIC CHIP 0.047uF	10% 16V	C64	1-164-217-11	CERAMIC CHIP 150PF	5% 50V
C23	1-162-915-11	CERAMIC CHIP 10PF	0.5PF 50V	C65	1-107-826-91	CERAMIC CHIP 0.1uF	10% 16V
C24	1-164-227-11	CERAMIC CHIP 0.022uF	10% 25V	C66	1-164-245-11	CERAMIC CHIP 0.015uF	10% 25V
C25	1-164-315-11	CERAMIC CHIP 470PF	5% 50V	C80	1-115-156-11	CERAMIC CHIP 1uF	10V
C26	1-162-919-11	CERAMIC CHIP 22PF	5% 50V	C81	1-115-156-11	CERAMIC CHIP 1uF	10V
C27	1-165-176-11	CERAMIC CHIP 0.047uF	10% 16V	C101	1-125-984-21	TANTAL. CHIP 22uF	20% 4V
C28	1-162-923-11	CERAMIC CHIP 47PF	5% 50V	C104	1-113-619-11	CERAMIC CHIP 0.47uF	10% 6.3V
C29	1-162-970-11	CERAMIC CHIP 0.01uF	10% 25V	C105	1-115-156-11	CERAMIC CHIP 1uF	10V
C30	1-162-961-11	CERAMIC CHIP 330PF	10% 50V	C106	1-113-619-11	CERAMIC CHIP 0.47uF	10% 6.3V
C31	1-164-362-11	CERAMIC CHIP 470PF	5% 50V	C107	1-115-467-11	CERAMIC CHIP 0.22uF	10% 10V
C32	1-125-984-21	TANTAL. CHIP 22uF	20% 4V	C108	1-115-156-11	CERAMIC CHIP 1uF	10V
C33	1-115-156-11	CERAMIC CHIP 1uF	10V	C110	1-164-677-11	CERAMIC CHIP 0.033uF	10% 16V
C34	1-115-156-11	CERAMIC CHIP 1uF	10V	C111	1-164-227-11	CERAMIC CHIP 0.022uF	10% 25V
C35	1-162-970-11	CERAMIC CHIP 0.01uF	10% 25V	C201	1-125-984-21	TANTAL. CHIP 22uF	20% 4V
				C204	1-113-619-11	CERAMIC CHIP 0.47uF	10% 6.3V
				C205	1-115-156-11	CERAMIC CHIP 1uF	10V

Ref. No.	Part No.	Description	Remark	Ref. No.	Part No.	Description	Remark
C206	1-115-156-11	CERAMIC CHIP	1uF	10V			
C207	1-113-619-11	CERAMIC CHIP	0.47uF	10%	6.3V		
C208	1-115-467-11	CERAMIC CHIP	0.22uF	10%	10V		
C210	1-164-677-11	CERAMIC CHIP	0.033uF	10%	16V		
C211	1-164-227-11	CERAMIC CHIP	0.022uF	10%	25V		
C301	1-119-663-11	TANTAL. CHIP	47uF	20%	2.5V		
C302	1-107-815-11	TANTAL. CHIP	2.2uF	20%	4V		
C303	1-164-360-11	CERAMIC CHIP	0.1uF		16V		
C304	1-125-984-21	TANTAL. CHIP	22uF	20%	4V		
C305	1-125-984-21	TANTAL. CHIP	22uF	20%	4V		
C306	1-113-619-11	CERAMIC CHIP	0.47uF	10%	6.3V		
C307	1-117-181-11	TANTAL. CHIP	4.7uF	20%	2.5V		
C308	1-117-181-11	TANTAL. CHIP	4.7uF	20%	2.5V		
C309	1-135-149-21	TANTAL. CHIP	2.2uF	20%	10V		
C310	1-164-360-11	CERAMIC CHIP	0.1uF		16V		
C311	1-165-112-11	CERAMIC CHIP	0.33uF		16V		
C312	1-165-128-11	CERAMIC CHIP	0.22uF		16V		
C313	1-115-156-11	CERAMIC CHIP	1uF		10V		
C314	1-165-128-11	CERAMIC CHIP	0.22uF		16V		
C315	1-115-156-11	CERAMIC CHIP	1uF		10V		
C316	1-162-968-11	CERAMIC CHIP	0.0047uF	10%	50V		
C317	1-162-964-11	CERAMIC CHIP	0.001uF	10%	50V		
C318	1-135-201-11	TANTAL. CHIP	10uF	20%	4V		
C319	1-164-360-11	CERAMIC CHIP	0.1uF		16V		
C320	1-164-227-11	CERAMIC CHIP	0.022uF	10%	25V		
C321	1-164-227-11	CERAMIC CHIP	0.022uF	10%	25V		
C325	1-125-837-11	CERAMIC CHIP	1uF	10%	6.3V		
C601	1-125-837-11	CERAMIC CHIP	1uF	10%	6.3V		
C602	1-107-826-11	CERAMIC CHIP	0.1uF	10%	16V		
C603	1-115-467-11	CERAMIC CHIP	0.22uF	10%	10V		
C604	1-164-360-11	CERAMIC CHIP	0.1uF		16V		
C605	1-107-826-11	CERAMIC CHIP	0.1uF	10%	16V		
C606	1-162-970-11	CERAMIC CHIP	0.01uF	10%	25V		
C607	1-162-970-11	CERAMIC CHIP	0.01uF	10%	25V		
C608	1-162-970-11	CERAMIC CHIP	0.01uF	10%	25V		
C803	1-135-177-21	TANTAL. CHIP	1uF	20%	20V		
C804	1-164-227-11	CERAMIC CHIP	0.022uF	10%	25V		
C805	1-125-837-11	CERAMIC CHIP	1uF	10%	6.3V		
C806	1-164-227-11	CERAMIC CHIP	0.022uF	10%	25V		
C807	1-125-984-21	TANTAL. CHIP	22uF	20%	4V		
C808	1-115-156-11	CERAMIC CHIP	1uF		10V		
C809	1-127-808-91	TANTAL. CHIP	10uF	20%	6.3V		
C810	1-162-970-11	CERAMIC CHIP	0.01uF	10%	25V		
C811	1-115-156-11	CERAMIC CHIP	1uF		10V		
C812	1-125-984-21	TANTAL. CHIP	22uF	20%	4V		
C813	1-115-156-11	CERAMIC CHIP	1uF		10V		
CB301	1-127-678-21	CERAMIC CHIP	330PF	0	50V		
		< FILTER >					
CF1	1-767-362-11	FILTER, CERAMIC (10.7MHz)					
CF2	1-767-480-11	FILTER, CERAMIC (AM) (450kHz)					
		< DIODE >					
D1	8-719-053-30	DIODE MA357 (E)-(TX).SO					
D2	8-719-053-30	DIODE MA357 (E)-(TX).SO					
D3	8-719-072-58	DIODE SVC347-TL					
D4	8-719-404-50	DIODE MA111-TX					
D5	8-719-049-09	DIODE 1SS367-T3SONY					
D6	8-719-422-37	DIODE MA8051-TX					
D101	8-719-422-37	DIODE MA8051-TX					
D201	8-719-422-37	DIODE MA8051-TX					
D301	8-719-422-37	DIODE MA8051-TX					
D302	8-719-422-37	DIODE MA8051-TX					
D303	8-719-422-37	DIODE MA8051-TX					
D304	8-719-422-37	DIODE MA8051-TX					
D305	8-719-422-37	DIODE MA8051-TX					
D801	8-719-049-09	DIODE 1SS367-T3SONY					
D802	8-719-420-87	DIODE MA8130-TX					
D803	8-719-404-50	DIODE MA111-TX					
D804	8-719-420-51	DIODE MA729-TX					
		< FUSE >					
F1	1-533-792-11	FUSE (SMD) 0.25A/125V					
		< FERRITE BEAD >					
FB1	1-500-445-21	FERRITE	0uH				
FB2	1-500-445-21	FERRITE	0uH				
FB3	1-500-445-21	FERRITE	0uH				
FB4	1-500-245-11	FERRITE	0uH				
FB5	1-500-245-11	FERRITE	0uH				
FB6	1-500-245-11	FERRITE	0uH				
FB7	1-500-245-11	FERRITE	0uH				
		< IC >					
IC1	8-759-362-23	IC TA7371AF-EL					
IC2	8-759-362-25	IC TA2022AFN-EL					
IC3	8-759-594-67	IC TC9327AF-606					
IC4	8-759-457-68	IC AK93C45AV-L					
IC5	8-759-387-31	IC TC75S55F (TE85R)					
IC6	8-759-457-70	IC XC62RP1602MR					
IC301	8-759-579-12	IC TA2123AF (EL)					
IC302	8-759-488-80	IC NJM2185AV-TE2					
IC601	8-759-356-46	IC MM1279XVBE					
IC801	8-759-553-28	IC XC6383C251ML					
		< JACK >					
J701	1-779-867-81	JACK (♁) REMOTE)					
		< SHORT >					
JC101	1-216-864-11	METAL CHIP	0	5%	1/16W	(EXCEPT FX673: FR)	
JC201	1-216-864-11	METAL CHIP	0	5%	1/16W	(EXCEPT FX673: FR)	
		< COIL >					
L1	1-469-373-21	INDUCTOR CHIP	95nH				
L2	1-416-941-21	COIL (FM OSC)					
L3	1-410-997-42	INDUCTOR CHIP	2.2uH				
L4	1-412-995-21	INDUCTOR CHIP	22uH				
L5	1-754-046-11	ANTENNA, FERRITE-ROD (AM)					
L6	1-412-995-21	INDUCTOR CHIP	22uH				
L7	1-412-967-31	INDUCTOR CHIP	0.1uH				
L8	1-412-967-31	INDUCTOR CHIP	0.1uH				
L801	1-412-034-11	INDUCTOR CHIP	330uH				
L802	1-412-995-21	INDUCTOR CHIP	22uH				

MAIN

Ref. No.	Part No.	Description	Remark	Ref. No.	Part No.	Description	Remark
L803	1-412-010-41	INDUCTOR CHIP 22uH		R15	1-216-833-11	RES,CHIP 10K 5%	1/16W
		< LIQUID CRYSTAL DISPLAY >		R16	1-216-853-11	METAL CHIP 470K 5%	1/16W
ND1	1-803-469-11	DISPLAY PANEL, LIQUID CRYSTAL		R17	1-216-821-11	METAL CHIP 1K 5%	1/16W
		< PHOTO REFLECTOR >		R18	1-216-849-11	METAL CHIP 220K 5%	1/16W
PH1	8-749-014-43	PHOTO REFLECTOR PR-20-T		R19	1-216-829-11	METAL CHIP 4.7K 5%	1/16W
		< TRANSISTOR >		R20	1-216-821-11	METAL CHIP 1K 5%	1/16W
Q1	8-729-037-89	TRANSISTOR 2SC4627J-C (TX).SO		R21	1-216-829-11	METAL CHIP 4.7K 5%	1/16W
Q2	8-729-028-69	TRANSISTOR 2SC4655-BC (TX)		R22	1-216-845-11	METAL CHIP 100K 5%	1/16W
Q3	8-729-037-89	TRANSISTOR 2SC4627J-C (TX).SO		R23	1-216-821-11	METAL CHIP 1K 5%	1/16W
Q4	8-729-037-89	TRANSISTOR 2SC4627J-C (TX).SO		R24	1-216-821-11	METAL CHIP 1K 5%	1/16W
Q5	8-729-231-96	FET 2SK880GR-TE85L		R25	1-216-845-11	METAL CHIP 100K 5%	1/16W
Q6	8-729-028-69	TRANSISTOR 2SC4655-BC (TX)		R26	1-216-833-11	RES,CHIP 10K 5%	1/16W
Q7	8-729-037-89	TRANSISTOR 2SC4627J-C (TX).SO		R27	1-216-853-11	METAL CHIP 470K 5%	1/16W
Q8	8-729-037-64	TRANSISTOR UN9116J-(TX).SO		R28	1-216-845-11	METAL CHIP 100K 5%	1/16W
Q9	8-729-823-86	TRANSISTOR 2SA1745-TL		R29	1-216-839-11	METAL CHIP 33K 5%	1/16W
Q10	8-729-037-89	TRANSISTOR 2SC4627J-C (TX).SO		R30	1-216-833-11	RES,CHIP 10K 5%	1/16W
Q11	8-729-037-63	TRANSISTOR UN9115J-(TX).SO		R31	1-216-843-11	METAL CHIP 68K 5%	1/16W
Q12	8-729-037-71	TRANSISTOR UN9210J-(TX).SO		R32	1-216-825-11	METAL CHIP 2.2K 5%	1/16W
Q13	8-729-037-71	TRANSISTOR UN9210J-(TX).SO		R33	1-216-825-11	METAL CHIP 2.2K 5%	1/16W
Q14	8-729-037-89	TRANSISTOR 2SC4627J-C (TX).SO		R34	1-216-857-11	METAL CHIP 1M 5%	1/16W
Q15	8-729-425-46	TRANSISTOR XP4315-TXE		R35	1-216-825-11	METAL CHIP 2.2K 5%	1/16W
Q16	8-729-013-60	TRANSISTOR UN9216J-(TX).SO		R36	1-216-849-11	METAL CHIP 220K 5%	1/16W
Q17	8-729-800-71	TRANSISTOR 2SB1295-UL6-TB		R37	1-216-857-11	METAL CHIP 1M 5%	1/16W
Q18	8-729-427-72	TRANSISTOR XP4501-TXE		R38	1-216-853-11	METAL CHIP 470K 5%	1/16W
Q19	8-729-426-36	TRANSISTOR XP1215-TXE		R39	1-216-815-11	METAL CHIP 330 5%	1/16W
Q20	8-729-037-71	TRANSISTOR UN9210J-(TX).SO		R40	1-216-833-11	RES,CHIP 10K 5%	1/16W
Q301	8-729-800-71	TRANSISTOR 2SB1295-UL6-TB		R41	1-218-871-11	RES,CHIP 10K 0.5%	1/16W
Q302	8-729-037-71	TRANSISTOR UN9210J-(TX).SO		R42	1-218-839-11	RES,CHIP 470 0.5%	1/16W
Q303	8-729-426-36	TRANSISTOR XP1215-TXE		R43	1-216-849-11	METAL CHIP 220K 5%	1/16W
Q304	8-729-037-62	TRANSISTOR UN9114J-(TX).SO		R44	1-216-851-11	METAL CHIP 330K 5%	1/16W
Q305	8-729-426-36	TRANSISTOR XP1215-TXE		R45	1-216-855-11	METAL CHIP 680K 5%	1/16W
Q601	8-729-037-71	TRANSISTOR UN9210J-(TX).SO		R46	1-216-821-11	METAL CHIP 1K 5%	1/16W
Q801	8-729-800-37	TRANSISTOR 2SD1048X6-TB		R47	1-216-823-11	METAL CHIP 1.5K 5%	1/16W
Q802	8-729-400-55	TRANSISTOR 2SD1328-S-TX		R48	1-218-863-11	RES,CHIP 4.7K 0.5%	1/16W
Q803	8-729-800-71	TRANSISTOR 2SB815B7-TB		R49	1-218-911-11	RES,CHIP 470K 0.5%	1/16W
Q804	8-729-800-71	TRANSISTOR 2SB815B7-TB		R50	1-218-855-11	RES,CHIP 2.2K 0.5%	1/16W
Q805	8-729-037-71	TRANSISTOR UN9210J-(TX).SO		R51	1-218-847-11	RES,CHIP 1K 0.5%	1/16W
		< RESISTOR >		R52	1-218-859-11	RES,CHIP 3.3K 0.5%	1/16W
R1	1-216-841-91	METAL CHIP 47K 5%	1/16W	R53	1-218-859-11	RES,CHIP 3.3K 0.5%	1/16W
R2	1-216-823-91	METAL CHIP 1.5K 5%	1/16W	R54	1-218-859-11	RES,CHIP 3.3K 0.5%	1/16W
R3	1-216-809-11	METAL CHIP 100 5%	1/16W	R55	1-218-863-11	RES,CHIP 4.7K 0.5%	1/16W
R4	1-216-825-11	METAL CHIP 2.2K 5%	1/16W	R56	1-218-875-11	RES,CHIP 15K 0.5%	1/16W
R5	1-216-821-11	METAL CHIP 1K 5%	1/16W	R58	1-216-833-11	RES,CHIP 10K 5%	1/16W
R6	1-216-817-11	METAL CHIP 470 5%	1/16W	R59	1-216-833-11	RES,CHIP 10K 5%	1/16W
R7	1-216-845-11	METAL CHIP 100K 5%	1/16W	R60	1-216-833-11	RES,CHIP 10K 5%	1/16W
R8	1-216-853-11	METAL CHIP 470K 5%	1/16W	R61	1-216-833-11	RES,CHIP 10K 5%	1/16W
R9	1-216-817-11	METAL CHIP 470 5%	1/16W	R62	1-216-845-11	METAL CHIP 100K 5%	1/16W
R10	1-216-829-11	METAL CHIP 4.7K 5%	1/16W	R63	1-216-853-11	METAL CHIP 470K 5%	1/16W
R11	1-216-833-11	RES,CHIP 10K 5%	1/16W	R64	1-216-853-11	METAL CHIP 470K 5%	1/16W
R12	1-216-833-11	RES,CHIP 10K 5%	1/16W	R65	1-216-849-11	METAL CHIP 220K 5%	1/16W
R13	1-216-837-11	METAL CHIP 22K 5%	1/16W	R66	1-216-839-11	METAL CHIP 33K 5%	1/16W
R14	1-216-845-11	METAL CHIP 100K 5%	1/16W	R67	1-216-839-11	METAL CHIP 33K 5%	1/16W
				R68	1-216-825-11	METAL CHIP 2.2K 5%	1/16W
				R69	1-216-825-11	METAL CHIP 2.2K 5%	1/16W
				R70	1-218-895-11	RES,CHIP 100K 0.5%	1/16W
				R71	1-218-851-11	RES,CHIP 1.5K 0.5%	1/16W
				R72	1-218-871-11	RES,CHIP 10K 0.5%	1/16W

Ref. No.	Part No.	Description	Remark	Ref. No.	Part No.	Description	Remark
R73	1-218-831-11	RES,CHIP	220 0.5% 1/16W	R803	1-216-817-11	METAL CHIP	470 5% 1/16W
R74	1-218-875-11	RES,CHIP	15K 0.5% 1/16W	R804	1-216-805-11	METAL CHIP	47 5% 1/16W
R75	1-218-839-11	RES,CHIP	470 0.5% 1/16W	R805	1-216-819-11	METAL CHIP	680 5% 1/16W
R76	1-218-875-11	RES,CHIP	15K 0.5% 1/16W				
R77	1-216-829-11	METAL CHIP	4.7K 5% 1/16W	R806	1-216-819-11	METAL CHIP	680 5% 1/16W
R101	1-216-823-11	METAL CHIP	1.5K 5% 1/16W	R807	1-216-845-11	METAL CHIP	100K 5% 1/16W
R102	1-216-837-11	METAL CHIP	22K 5% 1/16W			< COMPOSITION CIRCUIT BLOCK >	
R103	1-216-789-11	METAL CHIP	2.2 5% 1/16W				
R104	1-216-827-11	METAL CHIP	3.3K 5% 1/16W	RB1	1-233-811-21	RES, NETWORK 470K (3216)	
				RB601	1-233-873-21	RES, NETWORK 220K (CHIP TYPE) (3216)	
R105	1-216-823-11	METAL CHIP	1.5K 5% 1/16W			< VARIABLE RESISTOR >	
R106	1-216-811-11	METAL CHIP	150 5% 1/16W				
			(EXCEPT FX673: FR)	RV1	1-223-587-11	RES, ADJ, CARBON 22K	
R106	1-216-821-11	METAL CHIP	1K 5% 1/16W	RV301	1-225-684-21	RES, VAR, CARBON 30K/30K (VOL)	
			(FX673: FR)	RV601	1-223-584-11	RES, ADJ, CARBON 2.2K	
R107	1-216-837-11	METAL CHIP	22K 5% 1/16W			< SWITCH >	
R108	1-216-811-11	METAL CHIP	150 5% 1/16W				
R109	1-216-831-11	METAL CHIP	6.8K 5% 1/16W	S1	1-771-475-21	SWITCH, SLIDE (DIRECTION)	
R110	1-216-825-11	METAL CHIP	2.2K 5% 1/16W	S2	1-572-922-11	SWITCH, SLIDE (HOLD)	
R111	1-216-849-11	METAL CHIP	220K 5% 1/16W	S3	1-771-053-21	SWITCH, KEY BOARD (■ RADIO OFF)	
				S4	1-771-053-21	SWITCH, KEY BOARD	
R112	1-216-807-11	METAL CHIP	68 5% 1/16W			(TUNE/PRESET +, FF AMS)	
			(FX673: FR)	S5	1-771-053-21	SWITCH, KEY BOARD	
R201	1-216-823-11	METAL CHIP	1.5K 5% 1/16W			(TUNE/PRESET -, REW AMS)	
R202	1-216-837-11	METAL CHIP	22K 5% 1/16W	S6	1-771-053-21	SWITCH, KEY BOARD (MENU)	
R203	1-216-789-11	METAL CHIP	2.2 5% 1/16W	S7	1-771-053-21	SWITCH, KEY BOARD (SET)	
R204	1-216-827-11	METAL CHIP	3.3K 5% 1/16W	S8	1-771-053-21	SWITCH, KEY BOARD (BAND, RADIO ON)	
R205	1-216-823-11	METAL CHIP	1.5K 5% 1/16W	S9	1-771-053-21	SWITCH, KEY BOARD (◀▶ REPEAT)	
R206	1-216-811-11	METAL CHIP	150 5% 1/16W	S10	1-771-053-21	SWITCH, KEY BOARD	
			(EXCEPT FX673: FR)			(ENTER, COUNTER RESET)	
R206	1-216-821-11	METAL CHIP	1K 5% 1/16W			< TRANSFORMER >	
			(FX673: FR)	T1	1-416-943-21	COIL (AM OSC)	
R207	1-216-837-11	METAL CHIP	22K 5% 1/16W	T2	1-416-942-21	COIL (AM IF)	
R208	1-216-811-11	METAL CHIP	150 5% 1/16W	T801	1-423-745-11	TRANSFORMER, DC-DC CONVERTER	
R209	1-216-831-11	METAL CHIP	6.8K 5% 1/16W			< THERMISTOR >	
R210	1-216-825-11	METAL CHIP	2.2K 5% 1/16W	THP601	1-810-794-11	THERMISTOR, POSITIVE	
R211	1-216-849-11	METAL CHIP	220K 5% 1/16W			< VIBRATOR >	
			(FX673: FR)	X1	1-767-357-11	FILTER, CERAMIC (10.7MHz)	
R212	1-216-807-11	METAL CHIP	68 5% 1/16W	X2	1-579-615-11	VIBRATOR, CRYSTAL (75kHz)	
			(FX673: FR)			*****	
R301	1-216-849-11	METAL CHIP	220K 5% 1/16W			MISCELLANEOUS	
R302	1-216-833-11	RES,CHIP	10K 5% 1/16W			*****	
R303	1-216-835-11	METAL CHIP	15K 5% 1/16W	HP901	1-500-576-11	HEAD, MAGNETIC (PLAYBACK)	
R304	1-216-837-11	METAL CHIP	22K 5% 1/16W	M601	1-763-166-12	MOTOR (CAPSTAN/REEL)	
				PM901	1-454-674-32	SOLENOID, PLUNGER	
R305	1-216-789-11	METAL CHIP	2.2 5% 1/16W	S901	1-762-553-11	SWITCH, LEAF (TAPE DETECT, ATS)	
R306	1-216-851-11	METAL CHIP	330K 5% 1/16W			*****	
R307	1-216-825-11	METAL CHIP	2.2K 5% 1/16W			ACCESSORIES & PACKING MATERIALS	
R308	1-218-887-11	RES,CHIP	47K 0.5% 1/16W			*****	
R309	1-216-841-11	METAL CHIP	47K 5% 1/16W			1-418-019-11	REMOTE CONTROL UNIT (FX673)
						1-418-409-11	REMOTE CONTROL UNIT
R310	1-216-845-11	METAL CHIP	100K 5% 1/16W				(RM-WMF21) (FX877)
R311	1-216-841-11	METAL CHIP	47K 5% 1/16W	△	1-528-252-21	BATTERY CHARGER (BC-7S)	
R312	1-216-845-11	METAL CHIP	100K 5% 1/16W				(FX673: UK, E, HK)
R313	1-218-899-11	RES,CHIP	150K 0.5% 1/16W			1-528-299-41	BATTERY, NI-CD (NC-6WM) (FX673: CND)
R601	1-216-837-11	METAL CHIP	22K 5% 1/16W	△	1-528-434-13	BATTERY CHARGER (BC-7SG) (FX673: AUS)	
R602	1-216-809-11	METAL CHIP	100 5% 1/16W				
R603	1-216-829-11	METAL CHIP	4.7K 5% 1/16W				
R604	1-216-823-11	METAL CHIP	1.5K 5% 1/16W				
R605	1-216-833-11	RES,CHIP	10K 5% 1/16W				
R607	1-216-845-11	METAL CHIP	100K 5% 1/16W				
R801	1-216-849-11	METAL CHIP	220K 5% 1/16W				
R802	1-216-829-11	METAL CHIP	4.7K 5% 1/16W				

The components identified by mark △ or dotted line with △ are critical for safety. Replace only with part number specified.	Les composants identifiés par une marque △ sont critiques pour la sécurité. Ne les remplacer que par une pièce portant le numéro spécifié.
---	--

WM-FX673/FX877

Ref. No.	Part No.	Description	Remark
	1-528-543-11	BATTERY, NICKEL CADMIUM (NC-6WM) (FX673: E, EA, HK, AUS/FX877: CH)	
	1-528-543-22	BATTERY, NICKEL CADMIUM (NC-6WM) (FX673: AEP, UK, E, FR, EE, EA, HK, AUS/ FX877)	
△	1-528-580-21	BATTERY CHARGER (BC-7HT) (FX877: JE)	
△	1-528-661-14	BATTERY CHARGER (BC-7DR) (FX877: KR)	
△	1-528-713-21	BATTERY CHARGER (BC-7DC) (FX673: CND)	
△	1-528-744-23	BATTERY CHARGER (BC-7DY) (FX673: AEP, FR, EE, EA)	
△	1-528-822-11	BATTERY CHARGER (BC-7DN) (FX877: CH)	
△	1-569-007-11	ADAPTOR, CONVERSION 2P (FX877: JE)	
	1-759-213-11	CASE, BATTERY (FX673: CND, E, EA, HK, AUS/FX877)	
	1-759-700-21	CASE, BATTERY (FX673: AEP, UK, FR, EE)	
	3-008-521-01	CASE, BATTERY CHARGE (FX673/FX877: CH, KR)	
	3-008-521-21	CASE, BATTERY CHARGE (FX877: JE)	
	3-029-236-01	CARD, WARRANTY (P10) (FX877: JE)	
	3-029-488-01	POUCH, CARRYING	
	3-864-890-11	MANUAL, INSTRUCTION (ENGLISH, FRENCH) (FX673: CND, AEP, UK, FR, EE, EA, AUS, CH)	
	3-864-890-21	MANUAL, INSTRUCTION (SPANISH, PORTUGUESE) (FX673: AEP, EE)	
	3-864-890-31	MANUAL, INSTRUCTION (GERMAN, ITALIAN) (FX673: AEP)	
	3-864-890-41	MANUAL, INSTRUCTION (DUTCH, SWEDISH) (FX673: AEP)	
	3-864-890-51	MANUAL, INSTRUCTION (FINNISH) (FX673: AEP)	
	3-864-890-61	MANUAL, INSTRUCTION (POLISH, RUSSIAN) (FX673: EE)	
	3-864-890-71	MANUAL, INSTRUCTION (ENGLISH, CHINESE) (FX673: E, HK)	
	3-864-890-81	MANUAL, INSTRUCTION (ARABIC, CHINESE) (FX673: EA, CH)	
	3-866-189-11	MANUAL, INSTRUCTION (ENGLISH, KOREAN) (FX877: KR)	
	3-866-189-21	MANUAL, INSTRUCTION (JAPANESE, ENGLISH, KOREAN, CHINESE) (FX877: JE)	
	3-866-189-31	MANUAL, INSTRUCTION (ENGLISH, CHINESE) (FX877: CH)	
	8-953-272-90	HEADPHONE MDR-ED136SP//K SET (FX673: AEP, UK, E, FR, CET, EA, HK, AUS/ FX877: KR)	
	8-953-304-90	RECEIVER MDR-E805SP SET (FX673: CND/FX877: CH, JE)	

The components identified by mark △ or dotted line with mark △ are critical for safety. Replace only with part number specified.

Les composants identifiés par marque △ sont critiques pour la sécurité. Ne les remplacer que par une pièce portant le numéro spécifié.